

Fascia & Soffit Systems Installation Guide

Soffit installation:

Step 1:

Each soffit or fascia panel's protective film is printed with directional arrows. Ensure panels are fixed with the arrows pointing in the same direction to ensure a uniform surface appearance. Remove a small area of the protective film from the locations of all fixings to prevent it being trapped underneath the head of the fixing. See Fig. 1

Step 2:

Fix Soffit support trim FF30 to background at 600mm centres and slot soffit panel into Soffit support trim FF30. Pre-drill pilot holes and fix soffit at 600mm centres in rafter / truss ends with colour matched polypins, code SC670 at the front. Polypins should be positioned to be concealed by the bottom front return edge of the fascia. See Fig. 2

Step 3:

Joints between abutting panels are made using 'H' section joint trims. See Fig. 2

Step 4:

Install next soffit panel; ensure a 4mm expansion gap between panels. Fix horizontal timber battens between rafters / trusses for support and alignment at joints.

Fig. 1

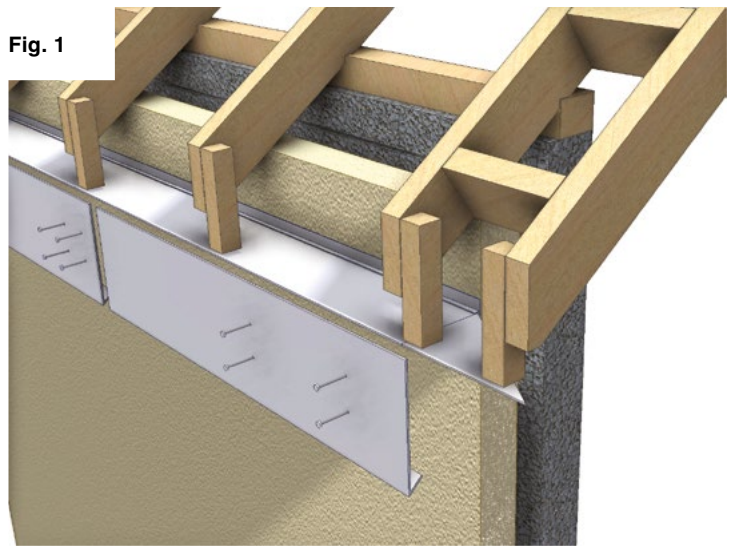

Fixing - Maximum 600mm centres

Fig. 2

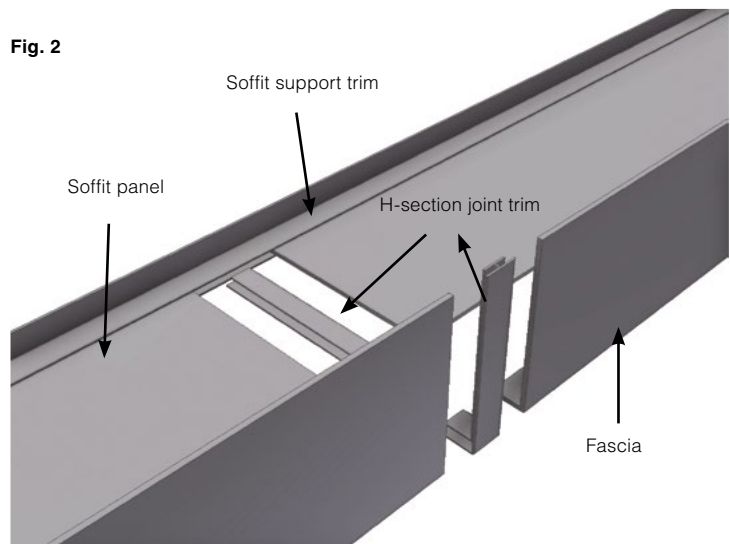

Jointing - Straight sections

Fig. 3

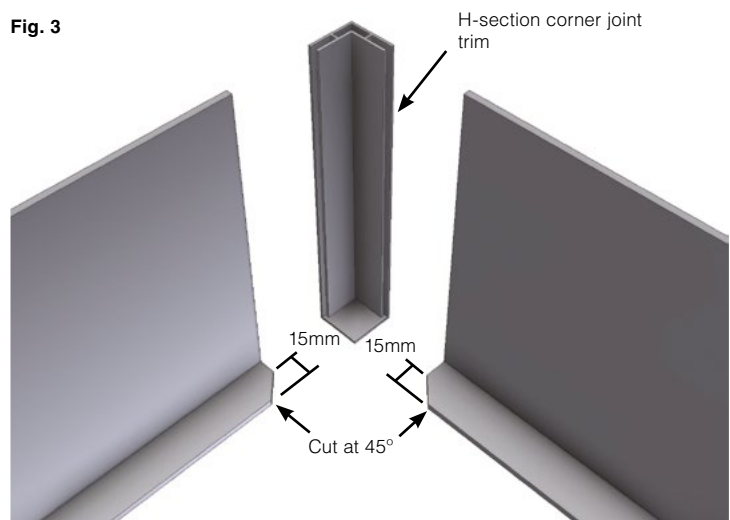

Angle joint - Cut fascia returns 15mm from front face at 45°

Fascia installation option 1: Mechanical fixing

Step 4.1: Option

Direct fixing to rafters: For fascia panels supporting guttering, fix with two Nr 50mm poly nails SC280 above the gutter line at maximum 600mm centres. For fascia panels not supporting guttering, fix with two Nr 30mm polypins SC670 at maximum 600mm centres. Additional polypin fixings will be required for fascias over 250mm deep.

Step 4.2: Option

Fixing to timber background: Fix fascia panel at maximum 600mm centres with two Nr 30mm polypins SC670 above the gutter line.

Step 5:

Abutting ends must be jointed with the appropriate H-Section joint trim.

Step 6:

Ensure there is at least a 2mm expansion gap where fascia panel is inserted into the H-section joint trim.

Step 7:

Finally, remove the protective film within 90 days of installation.

Fig. 4

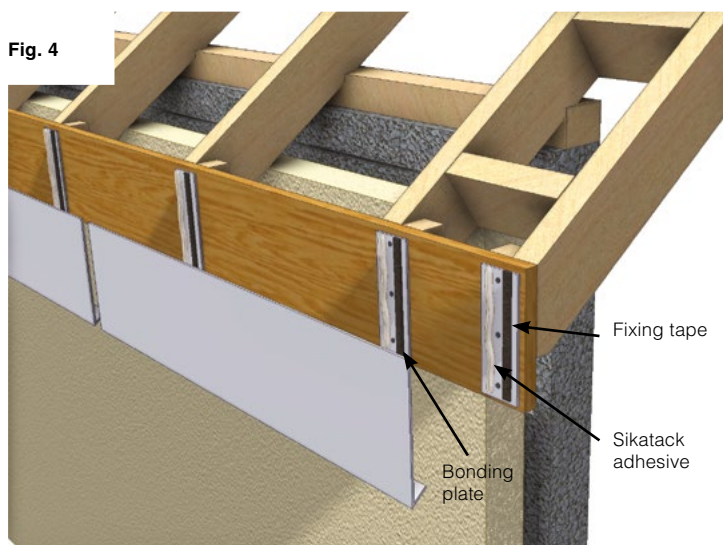

Bonding fascia option - Plates at maximum 600mm centres

Fig. 5

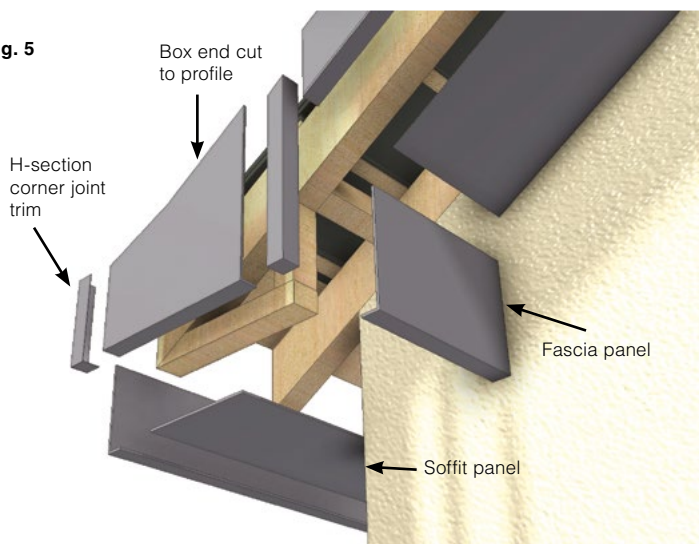

Typical box end construction

Fig. 6

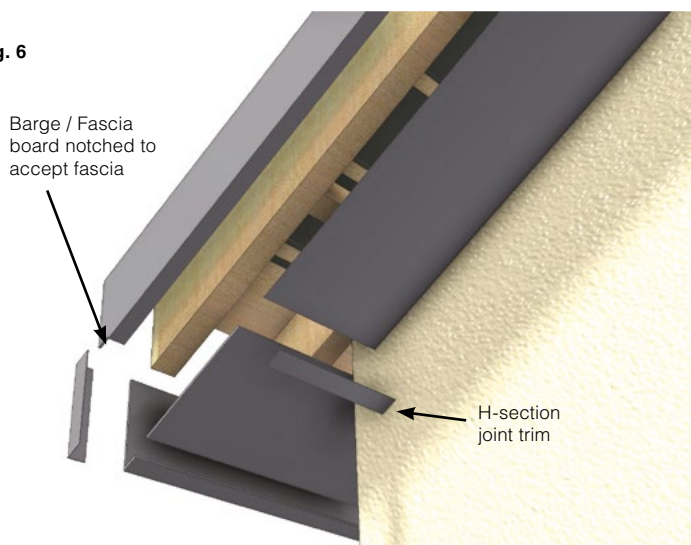

Angled soffit box end construction

Fascia installation option 2: Bonding

Marley Alutec recommends the use of SikaTack Panel Adhesive System when bonding panels.

Not all backgrounds are suitable for a direct secure bond, therefore bonding plates should be mechanically fixed to the background at maximum 600mm centres. Bonding plates are supplied 75mm wide in 3m lengths code FY40 for site cutting to required lengths.

Step 8:

Fix bonding plate FY40 at 600mm centres using minimum 3 Nr stainless steel flat head annular nails or countersunk screws.

Step 9:

Strip off the protective film from the bonding plates and apply one thin coat of SikaTack panel primer to the bonding plates and corresponding areas to the rear of the fascia board. Allow at least 30 minutes for the primer to dry.

Step 10:

Apply the self-adhesive fixing tape vertically to the full length of the bonding plate 5mm in from the edge. This fixing tape is only intended to hold the panel in position until the adhesive is fully cured. See Fig. 4.

Step 11:

Apply SikaTack adhesive to the bonding plate using the triangular nozzle supplied, applying a 10mm high bead at least 5mm from the edge of the plate.

Important Note: Do not apply adhesive in damp/wet conditions or temperatures below 5°C. We also recommend discreet pinning to the top edge to support the weight of the panels as an additional safety measure.

Step 12:

Remove the foil from the fixing tape, and then carefully offer the fascia panel into the required position to make contact with the beads of adhesive, but without touching the fixing tape. When the panel is in position, press firmly until it makes contact with the fixing tape. We recommend this operation is carried out by two operatives. Fitting the panel must be completed within 10 minutes after application of the adhesive.

Step 13.1: Option

H Section Joints: Abutting ends must be jointed with the appropriate H-Section joint trim.

Step 13.2: Option

Pointed Joints: To achieve a neat silicone joint apply masking tape to both edges, point silicone into the joint, code SC103 and smooth flat. Note: Silicone must make contact with the rear bonding plate. Finally remove masking tape.

Step 14:

Finally, remove the protective film within 90 days of installation.