

KNAUFINSULATION

ROCKSILK® RAINSCREEN FFCB
Installation guide

knaufinsulation.co.uk

What you need to know

Build on us.

Contents

Safety considerations	3
Typical systems	4
Pre-installation considerations	5
Placement	6
Installation sequence - Horizontal barriers	8
Installation sequence - Vertical barriers	9
Cutting	10
Detailing considerations	11
Fixings	15
Maintenance	15

Safety considerations

STORAGE

Rocksilk® RainScreen FFCB should be stored properly and handled in such a way as to ensure that it is clean and undamaged.

Rocksilk® RainScreen FFCB is supplied in cardboard boxes, hood wrapped on a pallet, designed for short-term protection only. For longer term protection on site the product should either be stored indoors or under cover and off the ground. Rocksilk® RainScreen FFCB should not be left permanently exposed to the elements.

If the main hood is removed or damaged, the boxes should be kept under cover indoors or protected from the elements by a weatherproof cover. In coastal locations where weather is more extreme and bird damage is more common, use additional covering or store indoors.

The product must be protected from prolonged exposure to sunlight, and stored dry and flat.

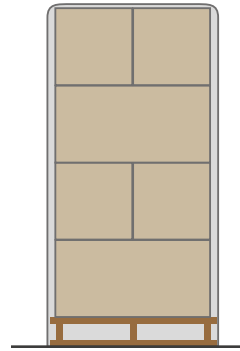

Barriers protected from weathering potential

HANDLING

Rocksilk® RainScreen FFCB is light and easy to handle; care should be exercised to avoid crushing the edges or corners. If damaged, the product should be discarded.

Damaged, contaminated or wet product must not be used.

During construction, exposed areas should always be covered at the end of a day's work or in heavy rain. Polyethylene covers should be used to provide protection and prevent work from becoming saturated.



Barriers exposed to the elements

SAFETY EQUIPMENT AND TOOLS

It is recommended that the following Personal Protective Equipment and tools should be used while handling the product:

PPE: Gloves, dust mask (FFP1 minimum), safety glasses

Tools: Drill, knife or fine-toothed saw, tape measure

It is recommended that dust masks, gloves and long-sleeved clothing should be worn during cutting and handling of the product.

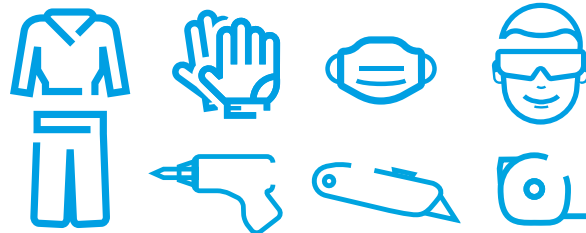

TIMBER FRAME

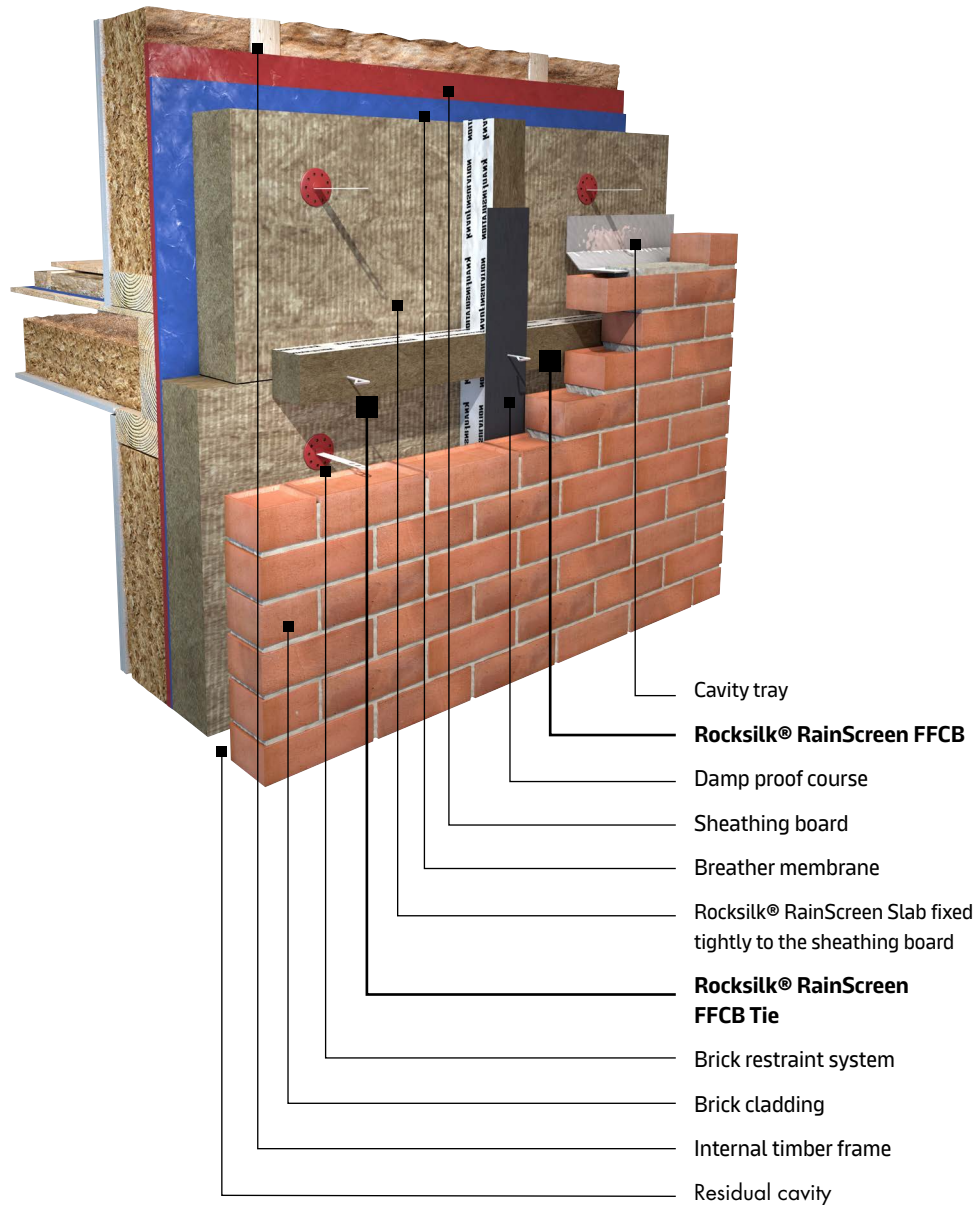

STEEL FRAME

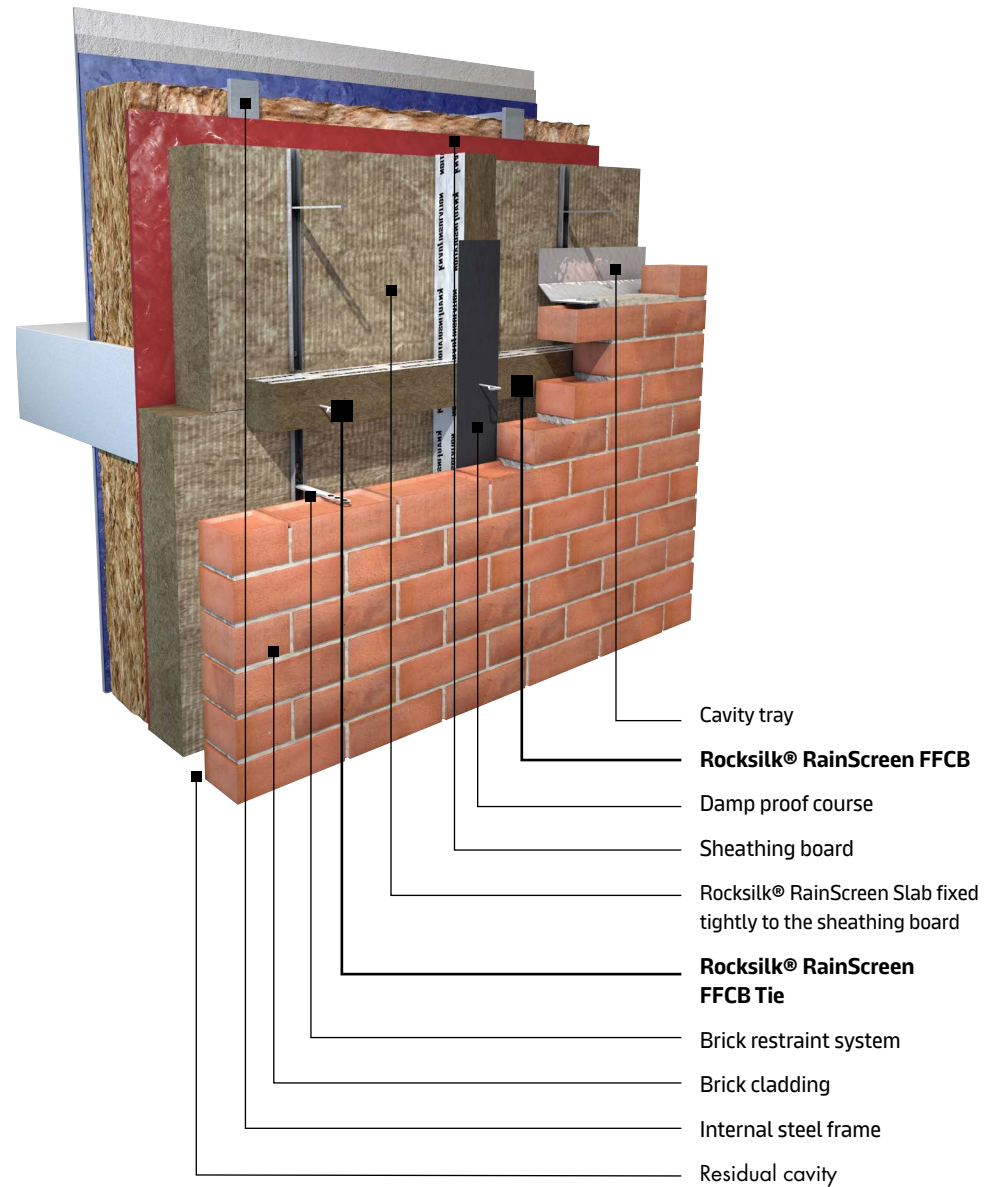

Pre-installation considerations

LAYOUT

Before installation of Rocksilk® RainScreen FFCB can commence, Rocksilk® RainScreen Slab sheathing insulation should be installed as per the installation instructions, available on our website.

- Slabs should be installed with joints staggered by a minimum 100mm
- Slabs should be tightly butted so there are no gaps
- Slabs should be held in full contact with the substrate either by the brick tie channels and fixings or by separate insulation fixings
- If brick tie channels are used, slabs should be installed in a landscape orientation

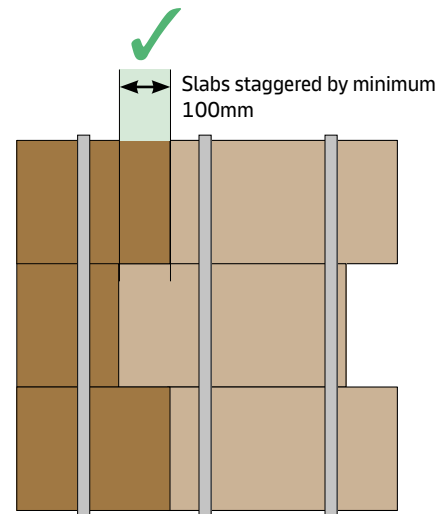
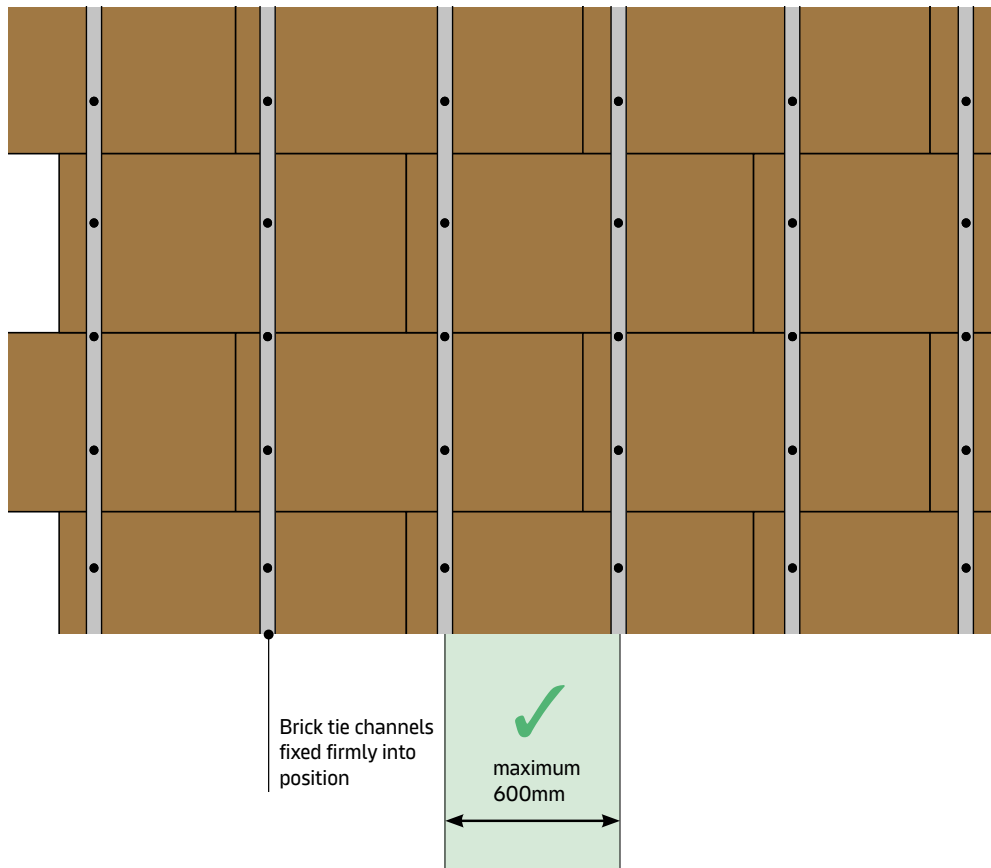

To avoid gaps between slabs



Placement

COMPRESSION

Rocksilk® RainScreen FFCB is designed to be friction fitted in place before the support fixing is positioned. Barriers should be 2mm wider than the residual cavity and installed from above to fit snugly between the masonry outer leaf and Rocksilk® RainScreen Slab sheathing insulation.

POSITION IN CAVITY

Rocksilk® RainScreen FFCB should be installed so that when friction fitted into the residual cavity it sits half way down the depth of the barrier against the brickwork. This allows for the support fixing to be installed through the centre of the barrier.

BARRIER ORIENTATION

Rocksilk® RainScreen FFCB should be installed so that the foil face is facing up into the cavity when installed as a horizontal cavity barrier, or to either side facing the cavity when installed as a vertical barrier. This ensures the rock mineral wool fibres are oriented correctly so the barrier can perform as specified.

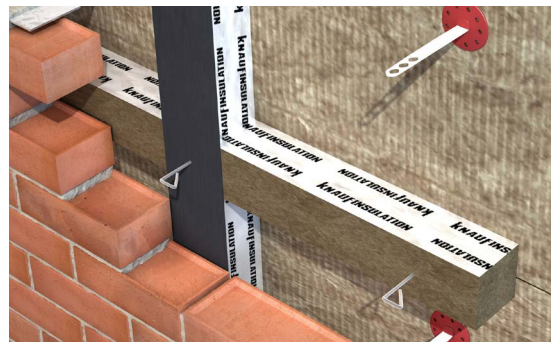
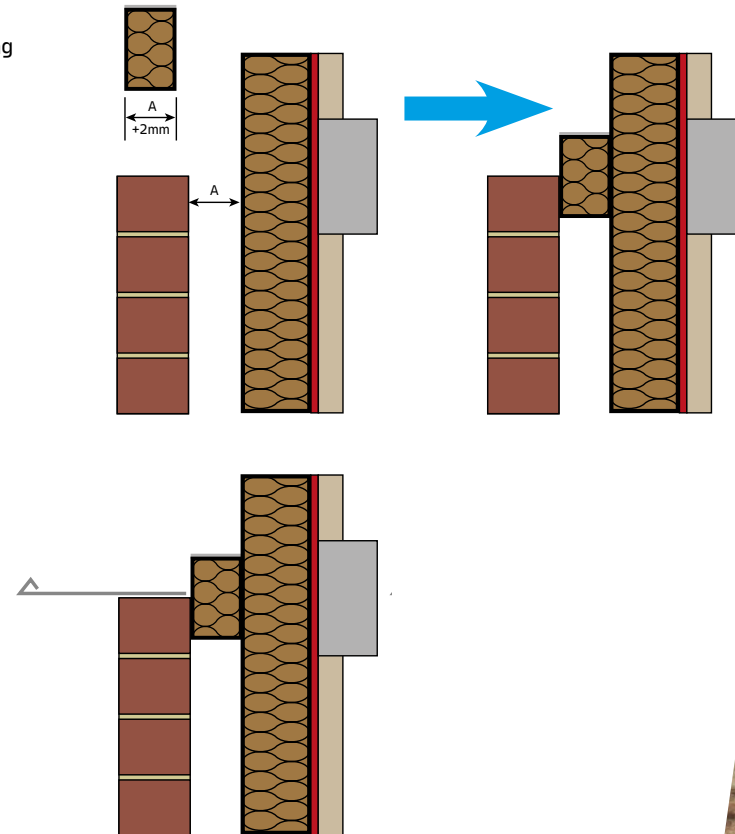

Placement

INTIMATE CONTACT WITH SUBSTRATE

Rocksilk® RainScreen FFCB should be in intimate contact with both substrates; the masonry façade and Rocksilk® RainScreen Slab. The nature of the material lends itself to accommodate minor irregularities in the surface of the substrate.

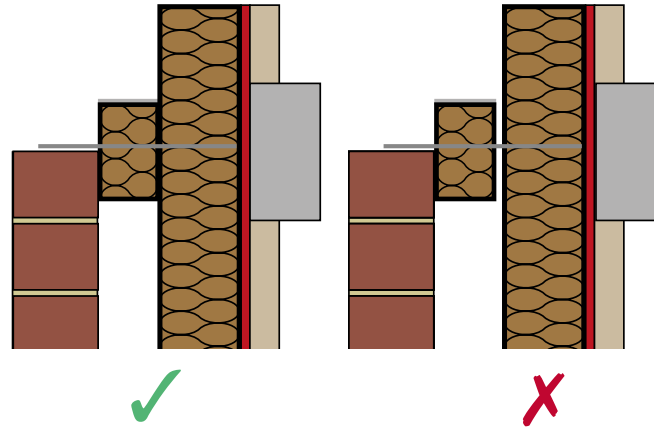

INTIMATE CONTACT WITH EACH OTHER

Rocksilk® RainScreen FFCB should be tightly butted together such that there are no gaps between the barriers.

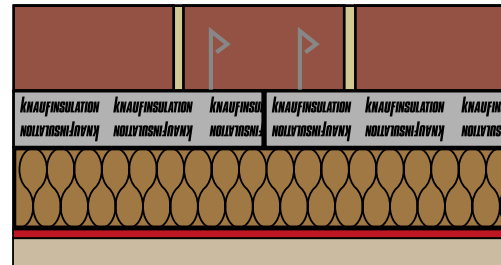

Installation sequence

HORIZONTAL BARRIER

Start by laying the brickwork outer leaf up to the level where the middle of the Rocksilk® RainScreen FFCB will be sat. This is to ensure there is enough contact between the barrier and Rocksilk® RainScreen Slab to allow a friction fit of the barrier into its final position.

Next, place Rocksilk® RainScreen FFCB in position such that it is sat with the middle of the barrier in line with the top layer of the brickwork.

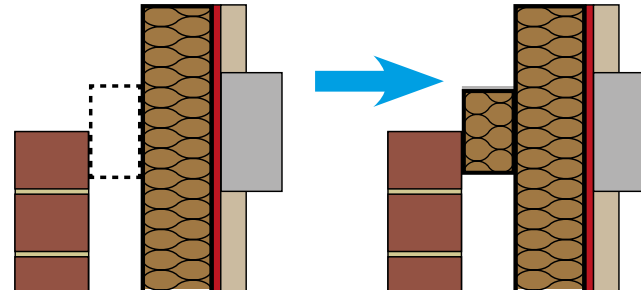

The support fixing should now be pressed through Rocksilk® RainScreen FFCB and Rocksilk® RainScreen Slab so that it touches against the sheathing board and should sit flush on top of the top layer of bricks. Rotate the fixings so that the triangle section is flat against the brickwork.

The support fixing should be embedded to a minimum of 30mm into the mortar bed.

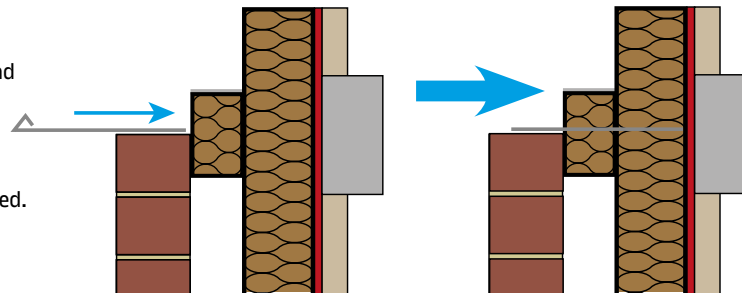

Fixings should be installed at maximum 500mm centres, ensuring at least 3 per 1200mm length of barrier.

The end fixings should be at a minimum 100mm from the edge of the barrier.

More than 3 fixings may also be used depending on preference.

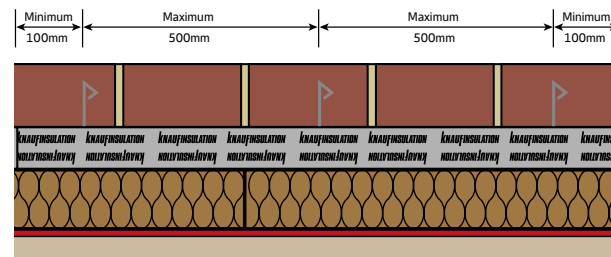

Continue laying the brickwork until Rocksilk® RainScreen FFCB is completely hidden.

The end of the support fixing should be embedded into the mortar joints.

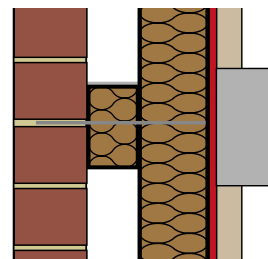

Installation sequence

VERTICAL BARRIER

Install the first two courses of bricks at floor level, or above a horizontal cavity barrier, so that there are two courses for Rocksilk® RainScreen FFCB to be fitted behind.

Rocksilk® RainScreen FFCB should be placed behind the brickwork. A temporary fixing can be placed at the top of the barrier to hold it against Rocksilk® RainScreen Slab while the rest of the brick façade is being constructed. A DPC should be placed between the vertical cavity barrier and masonry outer leaf.

A support fixing can now be pushed through Rocksilk® RainScreen FFCB, DPC and Rocksilk® RainScreen Slab so that it sits against the sheathing board and sits halfway through the depth of the brick.

The support fixing should be embedded to a minimum of 30mm into the mortar bed.

Fixings should be installed such that there are 3 fixings per barrier. Ensure the end fixings are no more than 100mm away from the edge of the barrier.

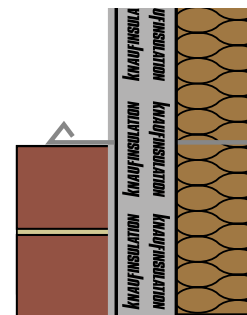
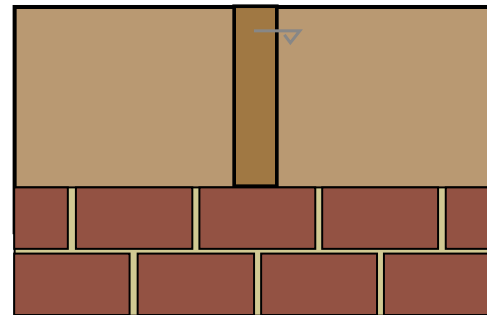
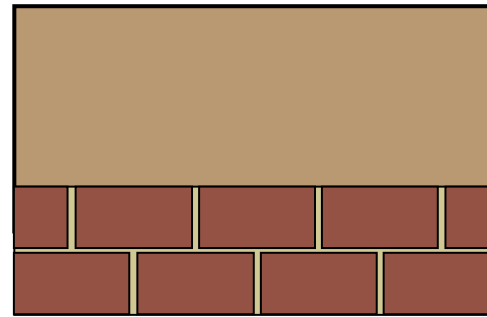

Cutting

FULL SLAB OR FACTORY FINISHED

Rocksilk® RainScreen FFCB can be supplied in a full slab format or factory finished to fit the required cavity dimensions before being delivered. The full slab format should be used in the event of non-uniform cavities or where cavity widths vary.

The full slab format should be cut neat and square following all of the advice above and be cut 2mm oversize to allow adequate compression.

CUT NEATLY WITH A SHARP INSULATION SAW/KNIFE OR CIRCULAR SAW

When supplied as a full slab or when cutting barriers to length, it is recommended that a first cut is done using a circular saw (or table saw) to provide a neat 90 degree cut and then finished off with a hand saw or large bladed knife. This is to ensure a neat edge to sit against the Rocksilk® RainScreen Slab and the outer leaf of brickwork. Rocksilk® RainScreen FFCB should not be installed if the edges of the barrier are not at a neat 90 degree cut.



Gives a factory quality cut and prevents tearing



Provides correct fitment between the insulation and brickwork



Rip using coarse blade or brick trowel creating an untidy cut

FULL BARRIER

Areas that cannot accept a full barrier can be filled using a smaller section that is cut slightly oversize by approximately 5mm and then compression fit into place. There should be a minimum of 2 fixings per slab section at a maximum of 500mm centres and no closer than 100mm to a barrier edge.

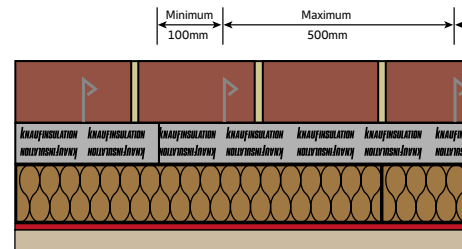

SQUARE CUTS

Care should be taken to ensure the cuts on Rocksilk® RainScreen FFCB are neat and square. To assist with this, using a circular saw to perform a first pass on the cut can help.



Detailing considerations

CAVITY WIDTH

Ensure a consistent cavity width is maintained throughout the construction, to avoid steps in the brickwork where Rocksilk® RainScreen FFCB is positioned. The cavity should be constructed to fit the designed cavity width and therefore the barrier width.

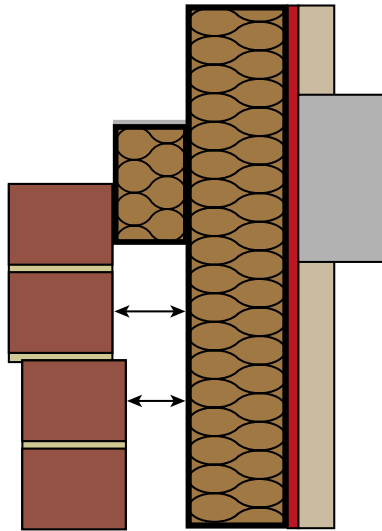

BRICK TIE CHANNELS

Brick tie channels used to secure Rocksilk® RainScreen Slab back to the building substrate should not penetrate through Rocksilk® RainScreen FFCB. Should it be necessary, the brick tie channel should be trimmed to allow for the installation of the barrier.

COINCIDENTAL JOINTS

Ensure there is no coincidental joints between Rocksilk® RainScreen Slab and Rocksilk® RainScreen FFCB, ensuring joints are staggered by minimum 100mm.

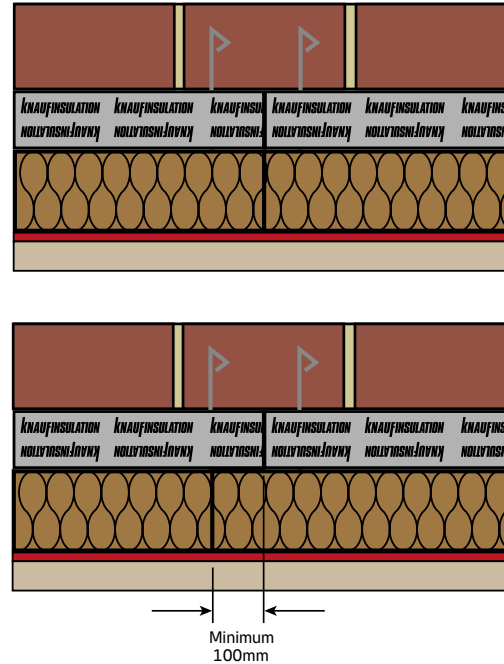

Detailing considerations

CAVITY TRAYS

Rocksilk® RainScreen FFCB does not act as a cavity tray. Cavity trays should be installed above the barriers in the course of brickwork, directly above the barriers so that moisture does not accumulate on the top of the barrier.

Ideally, a self-supporting cavity tray should be used that does not interfere with the Rocksilk® RainScreen Slab during installation.

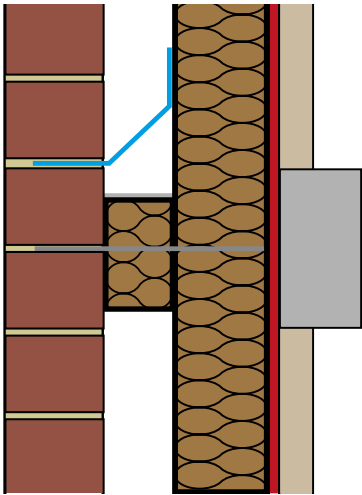

DPC'S

A vertical damp proof course should be installed between the face of the vertical Rocksilk® RainScreen FFCB and the outer leaf of masonry so that moisture cannot pass from the outer to inner leaf.

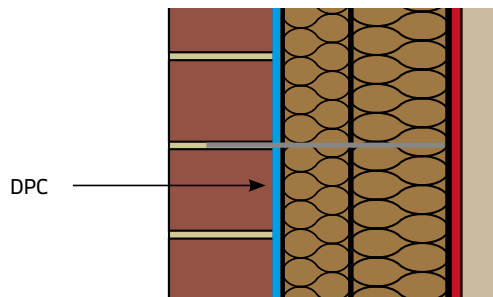

INTERACTIONS

Where vertical Rocksilk® RainScreen FFCBs interact with the cavity trays, it is recommended that the barriers remain continuous, and the cavity tray is broken.

The horizontal Rocksilk® RainScreen FFCB should remain continuous with the vertical Rocksilk® RainScreen FFCB, butting tightly to them.

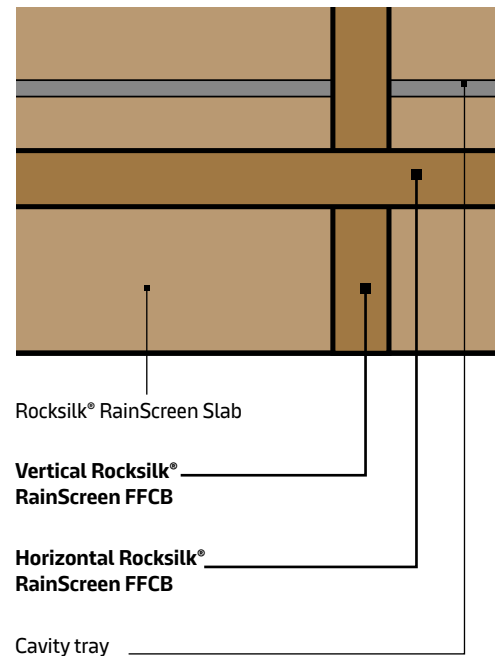

Detailing considerations

CORNERS

Rocksilk® RainScreen FFCBs should be cut neatly around corners so that they butt against each other and there are no gaps at joints.

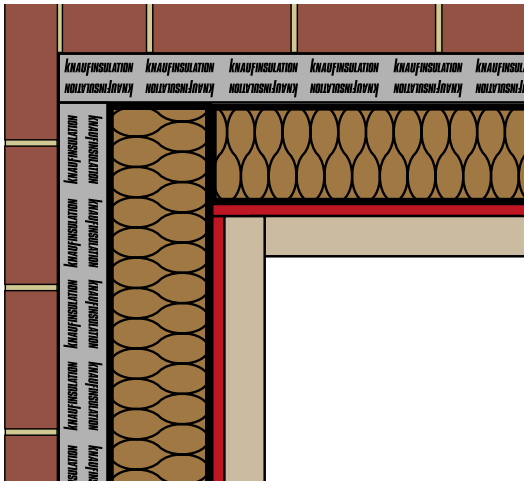

FIXINGS

Rocksilk® RainScreen FFCB Ties should be pushed through Rocksilk® RainScreen Slab so that they touch the sheathing board but do not need to be fixed directly to it. They should then be sat directly into the mortar joints of the brickwork which holds the barriers in place in the event of a fire. The support fixing should be embedded to a minimum of 30mm into the mortar bed.



PARTY WALLS

Rocksilk® RainScreen FFCB can be used as a cavity barrier for party walls where building regulations require a mineral wool cavity closer for acoustic, fire safety and thermal reasons. In this application the barrier is face-fixed to a continuous layer of Rocksilk® RainScreen Slab and acts as an effective edge seal minimising air and heat loss.

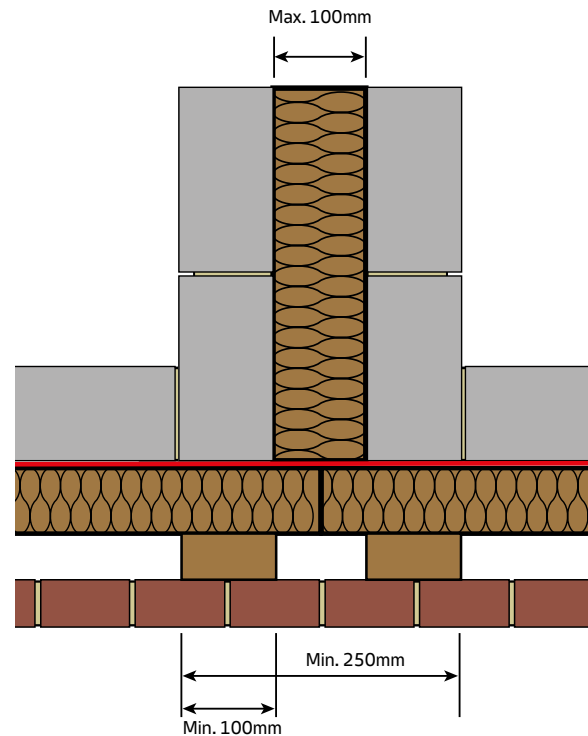

Detailing considerations

MASONRY SUPPORTS

Rocksilk® RainScreen FFCB has been tested for use with masonry support brackets using a 100mm and 150mm deep barrier using the following details.

Using these details, 100mm deep Rocksilk® RainScreen FFCB achieves 15 minutes insulation and 30 minutes integrity against a timber / steel frame or a masonry / concrete inner leaf, while 150mm deep Rocksilk® RainScreen FFCB achieves 30 minutes insulation and 30 minutes integrity.

100mm Rocksilk® RainScreen FFCB Details

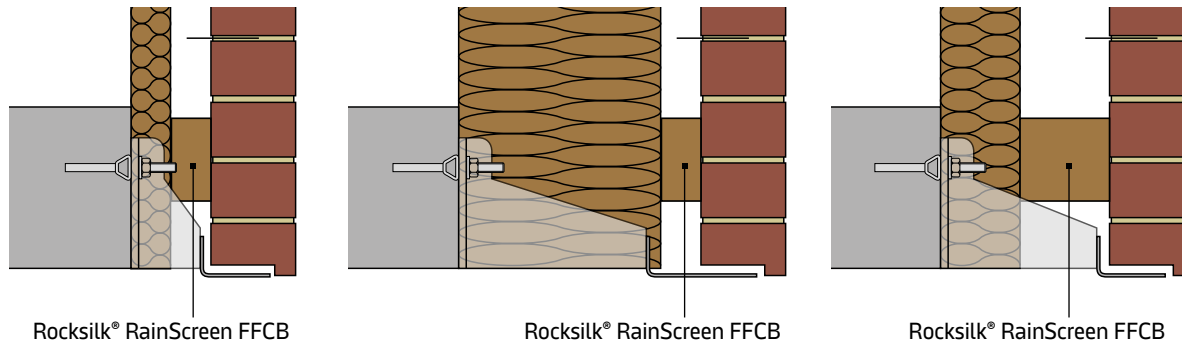

150mm Rocksilk® RainScreen FFCB Details

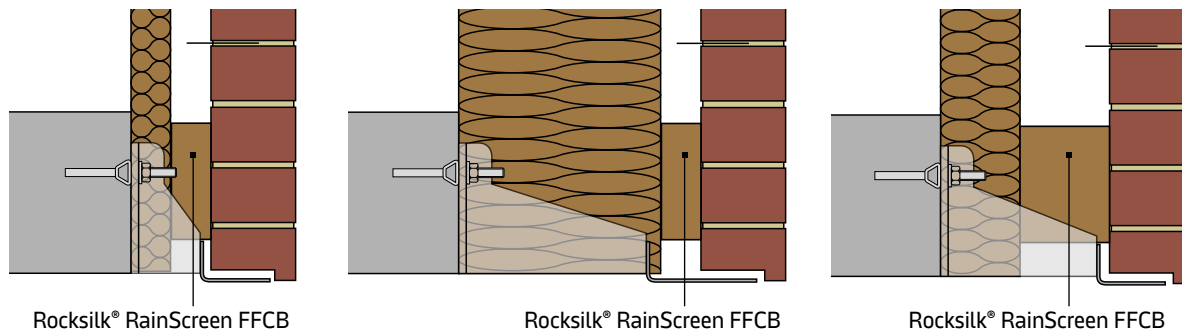

When installing Rocksilk® RainScreen FFCB around masonry supports, it is essential to completely fill the middle of the masonry support bracket with Rocksilk® RainScreen Slab so there is a uniform face of insulation for the cavity barrier to sit flush against. There must be no gaps running through the masonry support brackets which could let fire or heat pass through.



Fixings

LENGTHS

Rocksilk® RainScreen FFCB Ties are supplied in 200 / 300 or 400mm lengths and can be cut using tin snips or pliers to suit the depth of the Rocksilk® RainScreen Slab sheathing insulation. When using the full slab format, the fixings need to be ordered separately to Rocksilk® RainScreen FFCB.

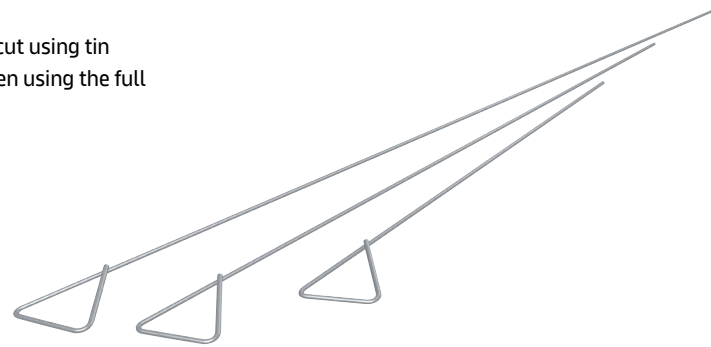

Maintenance

CONSTRUCTION REPAIRS

In the event of small repairs being needed on site, we recommend the replacement of full lengths of Rocksilk® RainScreen FFCB wherever possible.

Damaged Rocksilk® RainScreen FFCB should not be installed.



DURABILITY

Rocksilk® RainScreen FFCB is odourless, rot proof, non-hygroscopic, does not sustain vermin and will not encourage the growth of fungi, mould or bacteria. The product will have a life equivalent to that of the wall structure in which it is incorporated and has no long term maintenance requirements.





Technical Services Team

01744 766 666

technical.uk@knaufinsulation.com

For more information please visit

knaufinsulation.co.uk/rainscreen-solutions

Knauf Insulation Ltd

Stafford Road, St.Helens, Merseyside, WA10 3LZ Customer Service: 01744 766 766

All rights reserved, including those of photomechanical reproduction and storage in electronic media. Extreme caution was observed when putting together and processing the information, text and illustrations in this document. Nevertheless, errors cannot be completely ruled out. The publisher and editors cannot assume legal responsibility or any liability for incorrect information and consequences thereof. The publisher and editors will be grateful for improvement suggestions and details of possible errors pointed out. For the most up-to-date document versions and product information, please always refer to our website.

KINE4789DAT-V0624



Build on us.