



Single Skin Systems AS series roof & wall profiles



SINGLE SKIN SYSTEMS



AS24/1000



AS30/1000



AS35/1000

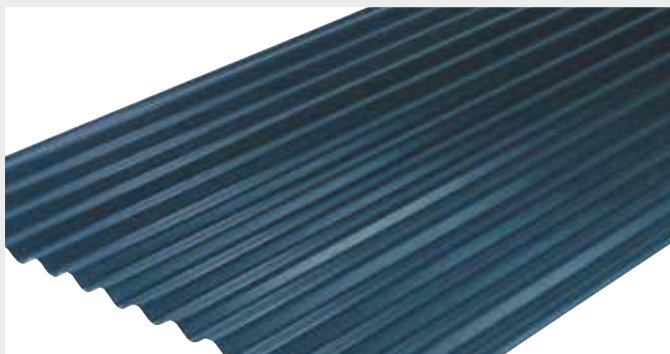

AS13/3/990

Contents

Introduction	3
Design and Certification	4
AS24/1000 profiles	6 - 7
AS30/1000 profiles	8 - 9
AS35/1000 profiles	10 - 11
AS13/3/990 profiles	12 - 13
Colour and Performance	14
Accessories	15 - 16
Design Guidance	17 - 19
Sitework	20 - 21
Installation	22 - 23
Construction Details	24 - 29
Maintenance	30
Technical Support	31

INTRODUCTION

About Steadmans

A Steadman & Son is one of the UK's leading manufacturers of roofing and cladding profiles, supplying high quality cladding materials across the whole of the UK.

We offer total single skin roofing and cladding solutions for your project and also supply a wide range of composite panels, twin skin systems and secondary steelwork including purlins, rails and eaves beams. We are always happy to provide advice on the specification of any of our products for your refurbishment and new build projects. Your project will benefit from our knowledge, expertise and technical acumen within the steel building sector. Steadmans is the complete one stop shop for metal roofing and cladding.

Steadmans Single Skin Systems

Steadmans' offer a self supporting steel profiled single skin cladding system suitable for both roof and walls. The profiles consist of a coated steel outer sheet rolled to one of our many Steadmans cladding profiles which can be used to form roofs down to 4° finished pitch (6° if rooflights are required) and for wall cladding. Steadmans single skin offering includes a comprehensive range of fixings, sealants, guttering, flashings and rooflights.



Durability

The Steadman profiles can be offered with a material warranties of up to 40 years -subject to the buildings location. Material warranty periods are reduced in industrial or coastal environments.

Darker finishes will fade more rapidly than light ones.

A table of colour options and material warranties are shown on page 14.

Fire

Steadmans roof and wall profiles achieve Class 1 surface spread of flame (Euroclass B), equivalent to Class 0 surface spread of flame as described in Approved Document B. All profiles are AA rated to BS 476-3:2004 & Broof (t4) to BS EN 13501-5.

Biological

The profiles are unaffected by mould, fungi and mildew. They do not support vermin.

Specification

NBS Plus is a library of technical product information written in NBS format, linked to NBS clauses and clause guidance.

NBS Plus

With NBS Plus, specifiers can select products quickly and accurately then drop the product information directly into a specification.

NBS clauses for Steadmans single skin roof and wall systems and other Steadmans products are now available for NBS subscribers.

All relevant BIM information is available from the national BIM Library.

Fragility Statement

When fully fixed and installed to Steadmans' recommendations (using correctly located fixings with 16mm bonded washers along with 6mm x 5mm NFRC class A butyl sealant at the end and side lap) the 0.5 or 0.7mm AS24 and AS30 external sheets achieve a Class B non-fragile assembly, as defined in the ACR(M)001:2014 'Test for non-fragility of profiles sheeted roofing assemblies' (third edition).

DESIGN AND CERTIFICATION

Steel profiles

Standard external weather sheets are available in 0.5mm and 0.7mm thicknesses.

The manufacturing tolerances are shown below. Standard profile dimensions, weights, and load spans are shown on pages 6 -13.

The steel used in the Steadmans roof and wall profiles is hot-dip galvanised to BS EN 10346:2009 or Aluzinc coated, then finished with one of the coatings listed in the table on page 14.

Profile dimensions	
Weight	
0.5mm thick	4.57 kg/m ²
0.7mm thick	6.49 kg/m ²

Manufacturing tolerances BE EN 508-1	
Length	+/-5mm
Cover width +/-5mm	+/-5mm
Squareness	3mm maximum



CE Marking

CE marking is mandatory for all single skin steel cladding systems covered by either a harmonised European Standard or a European Technical Assessment.

This became mandatory from July 1, 2013.

- This regulation is EU law and is being adopted by all member states, including the UK.
- The entire supply and distribution chain is responsible for ensuring correct CE marking on products.
- Manufacturers, importers, and distributors must be aware of essential characteristics and specification requirements of the product for the member state they are selling in.

Steadmans can supply certification of CE marking and a declaration of performance upon client request.



Quality Assured

We manufacture all of our products to the highest quality standard, operating a BSI accredited Quality Management System in compliance with the requirements of ISO 9001. Our products are manufactured from the highest-quality materials from our approved supply chain, using state-of-the-art production facilities which are rigorously controlled through inspection and testing at each production stage. Our products are designed and manufactured in accordance with all related and prevailing standards.

DESIGN AND CERTIFICATION



Environment

We operate a highly efficient manufacturing facility that operates an accredited Environmental Management System in compliance with the requirements of ISO 14001.

We are constantly focused on increasing our understanding and improving our products and processes we aim to recover and recycle all our waste. Our main raw material, steel, is eminently recyclable: 85 -90% of steel from demolition goes for re-use and 40% of steel used in new construction has been recycled.



Health & Safety

Our Business Delivery is managed efficiently and responsibly through the practise of our accredited Occupational Health and Safety Management System in compliance with the requirements of OHSAS 18001.

Through our Management System we promote a safe and healthy working environment by providing a framework that allows our organisation to identify and control its health and safety risks, reduce the potential for accidents, ensure legislative compliance and improve overall performance



AS SERIES ROOF & WALL PROFILES

AS24/1000 roof profile

A medium profile roof sheet available in 0.5mm and 0.7mm thicknesses.

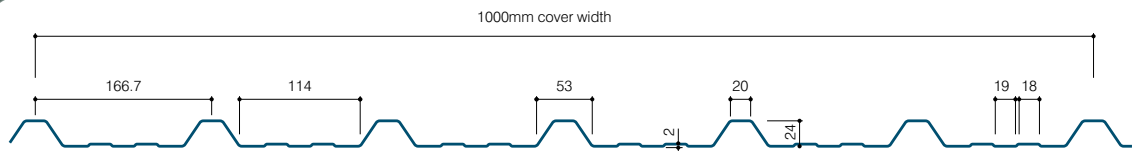

AS24/1000R steel roof profile • Thickness 0.5mm • Weight 4.57 kg/m²

Bottom flange in compression Moment capacity: 0.469 kNm/m Moment of inertia: 3.661 cm ⁴ /m		Bottom flange in tension Moment capacity: 0.457 kNm/m Moment of inertia: 3.673 cm ⁴ /m		Support width: 40mm Web crushing: 5.013 kN/m Youngs modulus E: 210 kN/mm ²													
Imposed load	Working load UDL (kN/m ²) Deflection limit L/200																
Span / m	1.20	1.30	1.40	1.50	1.60	1.70	1.80	1.90	2.00	2.10	2.20	2.30	2.40	2.50	2.60	2.70	2.80
Single	1.69	1.36	1.09	0.89	0.73	0.61	0.51	0.44	0.37	0.32	0.28	0.25	0.22	0.19	0.17	0.15	0.14
Double	1.46	1.28	1.12	1.00	0.89	0.80	0.73	0.66	0.60	0.54	0.47	0.41	0.36	0.32	0.28	0.25	0.23
Multiple	1.77	1.55	1.37	1.22	1.09	0.98	0.86	0.73	0.62	0.54	0.47	0.41	0.36	0.32	0.28	0.25	0.23
Bottom flange in compression Moment capacity: 0.457 kNm/m Moment of inertia: 3.673 cm ⁴ /m		Bottom flange in tension Moment capacity: 0.469 kNm/m Moment of inertia: 3.661 cm ⁴ /m		Support width: 40mm Web crushing: 5.013 kN/m Young modulus: 210 kN/mm ²													
Wind uplift load	Working load UDL (kN/m ²) Deflection limit L/90																
Span / m	1.20	1.30	1.40	1.50	1.60	1.70	1.80	1.90	2.00	2.10	2.20	2.30	2.40	2.50	2.60	2.70	2.80
Single	1.74	1.48	1.28	1.11	0.98	0.87	0.77	0.69	0.63	0.57	0.52	0.47	0.43	0.40	0.37	0.34	0.30
Double	1.43	1.25	1.10	0.98	0.88	0.79	0.71	0.65	0.59	0.54	0.50	0.46	0.42	0.39	0.36	0.33	0.31
Multiple	1.74	1.52	1.34	1.19	1.07	0.96	0.87	0.79	0.72	0.66	0.61	0.57	0.52	0.49	0.45	0.42	0.39
Bottom flange in compression Moment capacity: 0.469kNm/m Moment of inertia: 3.661 cm ⁴ /m		Bottom flange in tension Moment capacity: 0.457 kNm/m Moment of inertia: 3.673 cm ⁴ /m		Support width: 40mm Web crushing: 5.013 kN/m Youngs modulus E: 210 kN/mm ²													
Snow drift load	Working load UDL (kN/m ²) Deflection limit L/200																
Span / m	1.20	1.30	1.40	1.50	1.60	1.70	1.80	1.90	2.00	2.10	2.20	2.30	2.40	2.50	2.60	2.70	2.80
Single	2.54	2.16	1.87	1.62	1.43	1.27	1.13	1.01	0.91	0.83	0.76	0.69	0.63	0.58	0.54	0.50	0.47
Double	2.19	1.91	1.69	1.50	1.34	1.21	1.09	0.99	0.91	0.83	0.77	0.71	0.65	0.60	0.56	0.51	0.48
Multiple	2.65	2.32	2.05	1.82	1.63	1.47	1.33	1.21	1.11	1.02	0.94	0.87	0.80	0.75	0.69	0.64	0.60

AS24/1000R steel roof profile • Thickness 0.7mm • Weight 6.49kg/m²

Bottom flange in compression Moment capacity: 0.695 kNm/m Moment of inertia: 5.546 cm ⁴ /m		Bottom flange in tension Moment capacity: 0.695 kNm/m Moment of inertia: 5.546 cm ⁴ /m		Support width: 40mm Web crushing: 16.218 kN/m Youngs modulus E: 210 kN/mm ²													
Imposed load	Working load UDL (kN/m ²) Deflection limit L/200																
Span / m	1.20	1.30	1.40	1.50	1.60	1.70	1.80	1.90	2.00	2.10	2.20	2.30	2.40	2.50	2.60	2.70	2.80
Single	2.57	2.04	1.63	1.33	1.09	0.91	0.77	0.65	0.56	0.48	0.42	0.37	0.32	0.29	0.25	0.23	0.20
Double	2.37	2.06	1.81	1.60	1.43	1.28	1.14	1.03	0.93	0.80	0.70	0.61	0.54	0.48	0.42	0.38	0.34
Multiple	2.89	2.52	2.21	1.96	1.75	1.52	1.28	1.09	0.93	0.80	0.70	0.61	0.54	0.48	0.42	0.38	0.34
Bottom flange in compression Moment capacity: 0.695 kNm/m Moment of inertia: 5.546 cm ⁴ /m		Bottom flange in tension Moment capacity: 0.695 kNm/m Moment of inertia: 5.546 cm ⁴ /m		Support width: 40mm Web crushing: 16.218 kN/m Youngs modulus E: 210 kN/mm ²													
Wind uplift load	Working load UDL (kN/m ²) Deflection limit L/90																
Span / m	1.20	1.30	1.40	1.50	1.60	1.70	1.80	1.90	2.00	2.10	2.20	2.30	2.40	2.50	2.60	2.70	2.80
Single	2.57	2.19	1.89	1.65	1.45	1.28	1.14	1.03	0.93	0.84	0.77	0.70	0.64	0.59	0.55	0.5	0.45
Double	2.37	2.06	1.81	1.60	1.43	1.28	1.14	1.03	0.93	0.84	0.77	0.70	0.64	0.59	0.55	0.51	0.47
Multiple	2.89	2.52	2.21	1.96	1.75	1.57	1.42	1.28	1.16	1.05	0.96	0.88	0.8	0.74	0.69	0.64	0.59
Bottom flange in compression Moment capacity: 0.695 kNm/m Moment of inertia: 5.546 cm ⁴ /m		Bottom flange in tension Moment capacity: 0.695 kNm/m Moment of inertia: 5.546 cm ⁴ /m		Support width: 40mm Web crushing: 16.218 kN/m Youngs modulus E: 210 kN/mm ²													
Snow drift load	Working load UDL (kN/m ²) Deflection limit L/200																
Span / m	1.20	1.30	1.40	1.50	1.60	1.70	1.80	1.90	2.00	2.10	2.20	2.30	2.40	2.50	2.60	2.70	2.80
Single	3.68	3.13	2.70	2.35	2.07	1.83	1.63	1.47	1.32	1.20	1.09	1.00	0.92	0.85	0.78	0.73	0.68
Double	3.39	2.95	2.59	2.29	2.04	1.83	1.63	1.47	1.32	1.20	1.09	1.00	0.92	0.85	0.78	0.73	0.68
Multiple	4.13	3.59	3.16	2.80	2.50	2.24	2.02	1.83	1.65	1.50	1.37	1.25	1.15	1.06	0.98	0.91	0.84

Bold type: Spans between 1.20 -1.80m Non-fragile **Normal type:** Spans above 1.80m Fragile

AS SERIES ROOF & WALL PROFILES

AS24/1000 wall profile

A medium profile wall sheet available in 0.5mm and 0.7mm thicknesses.

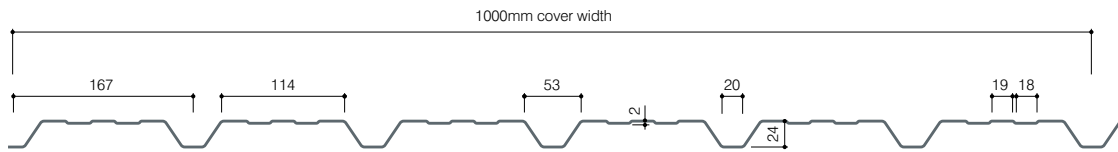

AS24/1000W steel wall profile • Thickness 0.5mm • Weight 4.57 kg/m²

Bottom flange in compression Moment capacity: 0.457 kNm/m Moment of inertia: 3.673 cm ⁴ /m				Bottom flange in tension Moment capacity: 0.469 kNm/m Moment of inertia: 3.661 cm ⁴ /m				Support width: 40mm Web crushing: 8.007 kN/m Youngs modulus E: 210 kN/mm ²									
Positive	Working load UDL (kN/m ²) Deflection limit L/90																
Span / m	1.20	1.30	1.40	1.50	1.60	1.70	1.80	1.90	2.00	2.10	2.20	2.30	2.40	2.50	2.60	2.70	2.80
Single	1.74	1.48	1.28	1.11	0.98	0.87	0.77	0.69	0.63	0.57	0.52	0.47	0.43	0.40	0.37	0.34	0.30
Double	1.43	1.25	1.10	0.98	0.88	0.79	0.71	0.65	0.59	0.54	0.50	0.46	0.42	0.39	0.36	0.33	0.31
Multiple	1.74	1.52	1.34	1.19	1.07	0.96	0.87	0.79	0.72	0.66	0.61	0.57	0.52	0.49	0.45	0.42	0.39
Bottom flange in compression Moment capacity: 0.469 kNm/m Moment of inertia: 3.661 cm ⁴ /m				Bottom flange in tension Moment capacity: 0.457 kNm/m Moment of inertia: 3.673 cm ⁴ /m				Support width: 40mm Web crushing: 8.007 kN/m Young modulus: 210 kN/mm ²									
Negative	Working load UDL (kN/m ²) Deflection limit L/90																
Span / m	1.20	1.30	1.40	1.50	1.60	1.70	1.80	1.90	2.00	2.10	2.20	2.30	2.40	2.50	2.60	2.70	2.80
Single	1.69	1.44	1.24	1.08	0.95	0.84	0.75	0.68	0.61	0.55	0.50	0.46	0.42	0.39	0.36	0.33	0.30
Double	1.46	1.28	1.12	1.00	0.89	0.80	0.73	0.66	0.60	0.55	0.51	0.47	0.43	0.40	0.37	0.34	0.32
Multiple	1.77	1.55	1.37	1.22	1.09	0.98	0.89	0.81	0.74	0.68	0.62	0.58	0.53	0.50	0.46	0.43	0.40

AS24/1000W steel wall profile • Thickness 0.7mm • Weight 6.49 kg/m²

Bottom flange in compression Moment capacity: 0.695 kNm/m Moment of inertia: 5.546 cm ⁴ /m				Bottom flange in tension Moment capacity: 0.695 kNm/m Moment of inertia: 5.546 cm ⁴ /m				Support width: 40mm Web crushing: 18.218 kN/m Youngs modulus E: 210 kN/mm ²									
Positive	Working load UDL (kN/m ²) Deflection limit L/90																
Span / m	1.20	1.30	1.40	1.50	1.60	1.70	1.80	1.90	2.00	2.10	2.20	2.30	2.40	2.50	2.60	2.70	2.80
Single	2.57	2.19	1.89	1.65	1.45	1.28	1.14	1.03	0.93	0.84	0.77	0.70	0.64	0.59	0.55	0.50	0.45
Double	2.37	2.06	1.81	1.60	1.43	1.28	1.14	1.03	0.93	0.84	0.77	0.70	0.64	0.59	0.55	0.51	0.47
Multiple	2.89	2.52	2.21	1.96	1.75	1.57	1.42	1.28	1.16	1.05	0.96	0.88	0.80	0.74	0.69	0.64	0.59
Bottom flange in compression Moment capacity: 0.695 kNm/m Moment of inertia: 5.546 cm ⁴ /m				Bottom flange in tension Moment capacity: 0.695 kNm/m Moment of inertia: 5.546 cm ⁴ /m				Support width: 40mm Web crushing: 18.218 kN/m Youngs modulus E: 210 kN/mm ²									
Negative	Working load UDL (kN/m ²) Deflection limit L/90																
Span / m	1.20	1.30	1.40	1.50	1.60	1.70	1.80	1.90	2.00	2.10	2.20	2.30	2.40	2.50	2.60	2.70	2.80
Single	2.57	2.19	1.89	1.65	1.45	1.28	1.14	1.03	0.93	0.84	0.77	0.70	0.64	0.59	0.55	0.50	0.45
Double	2.37	2.06	1.81	1.60	1.43	1.28	1.14	1.03	0.93	0.84	0.77	0.70	0.64	0.59	0.55	0.51	0.47
Multiple	2.89	2.52	2.21	1.96	1.75	1.57	1.42	1.28	1.16	1.05	0.96	0.88	0.80	0.74	0.69	0.64	0.59

BS EN 1991-1-4:

Appendix C.5.6.4: Partial safety factors for limit state design.
Load factors included within the load/span tables:

- Variable loads factor 1.5
- Permanent load factor 1.35
- Accidental load factor 1.0
- Serviceability load factor 1.0

Deflection

- Roofs - imposed loads - L/200
- Roofs - wind L/90
- Walls - wind L/90

AS SERIES ROOF & WALL PROFILES

AS30/1000 roof profile

A deep profile roof sheet available in 0.5mm and 0.7mm thicknesses. The male underlapping sheet edge has a support leg and an anti-siphonic groove.

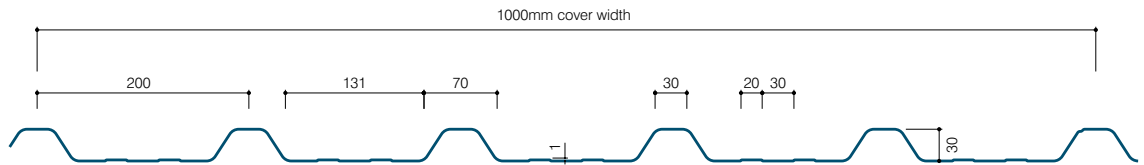

AS30/1000R steel roof profile • Thickness 0.5mm • Weight 4.57 kg/m²

Bottom flange in compression Moment capacity: 0.653 kNm/m Moment of inertia: 5.490 cm ⁴ /m		Bottom flange in tension Moment capacity: 0.582 kNm/m Moment of inertia: 5.866 cm ⁴ /m		Support width: 40mm Web crushing: 5.013 kN/m Youngs modulus E: 210 kN/mm ²														
Imposed load	Working load UDL (kN/m ²)		Deflection limit L/200															
Span / m	1.20	1.30	1.40	1.50	1.60	1.70	1.80	1.90	2.00	2.10	2.20	2.30	2.40	2.50	2.60	2.70	2.80	
Single	2.16	1.84	1.58	1.38	1.21	1.01	0.85	0.72	0.62	0.54	0.47	0.41	0.36	0.32	0.28	0.25	0.23	
Double	1.45	1.29	1.15	1.04	0.94	0.85	0.78	0.72	0.66	0.61	0.56	0.53	0.49	0.46	0.43	0.40	0.38	
Multiple	1.72	1.53	1.37	1.24	1.12	1.02	0.94	0.86	0.79	0.73	0.68	0.63	0.59	0.53	0.47	0.42	0.38	
Bottom flange in compression Moment capacity: 0.582 kNm/m Moment of inertia: 5.866 cm ⁴ /m		Bottom flange in tension Moment capacity: 0.653 kNm/m Moment of inertia: 5.490 cm ⁴ /m		Support width: 40mm Web crushing: 5.013 kN/m Young modulus: 210 kN/mm ²														
Wind uplift load	Working load UDL (kN/m ²)		Deflection limit L/90															
Span / m	1.20	1.30	1.40	1.50	1.60	1.70	1.80	1.90	2.00	2.10	2.20	2.30	2.40	2.50	2.60	2.70	2.80	
Single	2.42	2.06	1.78	1.55	1.36	1.21	1.07	0.96	0.87	0.79	0.72	0.66	0.60	0.56	0.52	0.48	0.44	
Double	1.37	1.21	1.08	0.97	0.88	0.80	0.73	0.67	0.61	0.57	0.52	0.49	0.45	0.42	0.40	0.37	0.35	
Multiple	1.63	1.45	1.29	1.16	1.05	0.96	0.88	0.80	0.74	0.68	0.63	0.59	0.55	0.51	0.48	0.45	0.42	
Bottom flange in compression Moment capacity: 0.653 kNm/m Moment of inertia: 5.490 cm ⁴ /m		Bottom flange in tension Moment capacity: 0.582 kNm/m Moment of inertia: 5.866 cm ⁴ /m		Support width: 40mm Web crushing: 5.013 kN/m Youngs modulus E: 210 kN/mm ²														
Snow drift load	Working load UDL (kN/m ²)		Deflection limit L/200															
Span / m	1.20	1.30	1.40	1.50	1.60	1.70	1.80	1.90	2.00	2.10	2.20	2.30	2.40	2.50	2.60	2.70	2.80	
Single	3.23	2.76	2.38	2.07	1.82	1.61	1.44	1.29	1.16	1.06	0.96	0.88	0.81	0.74	0.69	0.64	0.59	
Double	2.17	1.93	1.73	1.55	1.41	1.28	1.17	1.07	0.99	0.91	0.85	0.79	0.73	0.69	0.64	0.60	0.57	
Multiple	2.58	2.30	2.06	1.86	1.68	1.53	1.40	1.29	1.19	1.10	1.02	0.95	0.89	0.83	0.78	0.73	0.69	

AS30/1000R steel roof profile • Thickness 0.7mm • Weight 6.49 kg/m²

Bottom flange in compression Moment capacity: 0.986 kNm/m Moment of inertia: 8.956 cm ⁴ /m		Bottom flange in tension Moment capacity: 0.970 kNm/m Moment of inertia: 9.521 cm ⁴ /m		Support width: 40mm Web crushing: 10.965 kN/m Youngs modulus E: 210 kN/mm ²														
Imposed load	Working load UDL (kN/m ²)		Deflection limit L/200															
Span / m	1.20	1.30	1.40	1.50	1.60	1.70	1.80	1.90	2.00	2.10	2.20	2.30	2.40	2.50	2.60	2.70	2.80	
Single	3.59	3.06	2.64	2.30	1.89	1.58	1.33	1.13	0.97	0.84	0.73	0.64	0.56	0.50	0.44	0.39	0.35	
Double	2.61	2.30	2.04	1.83	1.64	1.49	1.35	1.24	1.13	1.04	0.96	0.89	0.83	0.77	0.72	0.66	0.59	
Multiple	3.13	2.76	2.46	2.20	1.98	1.80	1.64	1.50	1.37	1.27	1.17	1.06	0.94	0.83	0.74	0.66	0.59	
Bottom flange in compression Moment capacity: 0.970 kNm/m Moment of inertia: 9.521 cm ⁴ /m		Bottom flange in tension Moment capacity: 0.986 kNm/m Moment of inertia: 8.956 cm ⁴ /m		Support width: 40mm Web crushing: 10.965 kN/m Youngs modulus E: 210 kN/mm ²														
Wind uplift load	Working load UDL (kN/m ²)		Deflection limit L/90															
Span / m	1.20	1.30	1.40	1.50	1.60	1.70	1.80	1.90	2.00	2.10	2.20	2.30	2.40	2.50	2.60	2.70	2.80	
Single	3.65	3.11	2.68	2.34	2.05	1.82	1.62	1.46	1.31	1.19	1.09	0.99	0.91	0.84	0.78	0.72	0.67	
Double	2.59	2.28	2.02	1.81	1.63	1.47	1.34	1.22	1.12	1.03	0.95	0.88	0.82	0.76	0.71	0.67	0.63	
Multiple	3.10	2.74	2.43	2.18	1.96	1.78	1.62	1.48	1.36	1.25	1.16	1.07	1.00	0.93	0.87	0.82	0.77	
Bottom flange in compression Moment capacity: 0.986 kNm/m Moment of inertia: 8.956 cm ⁴ /m		Bottom flange in tension Moment capacity: 0.970 kNm/m Moment of inertia: 9.521 cm ⁴ /m		Support width: 40mm Web crushing: 10.965 kN/m Youngs modulus E: 210 kN/mm ²														
Snow drift load	Working load UDL (kN/m ²)		Deflection limit L/200															
Span / m	1.20	1.30	1.40	1.50	1.60	1.70	1.80	1.90	2.00	2.10	2.20	2.30	2.40	2.50	2.60	2.70	2.80	
Single	5.39	4.59	3.96	3.45	3.03	2.69	2.40	2.15	1.94	1.76	1.60	1.47	1.35	1.24	1.15	1.06	0.99	
Double	3.91	3.45	3.06	2.74	2.47	2.23	2.03	1.85	1.70	1.57	1.45	1.34	1.25	1.16	1.08	1.01	0.95	
Multiple	4.69	4.14	3.68	3.30	2.98	2.70	2.45	2.25	2.06	1.90	1.76	1.63	1.52	1.41	1.32	1.24	1.16	

Bold type: Spans between 1.20 -1.80m Non-fragile **Normal type:** Spans above 1.80m Fragile

AS SERIES ROOF & WALL PROFILES

AS30/1000 wall profile

A deep profiled wall sheet available in 0.5 and 0.7mm thicknesses.

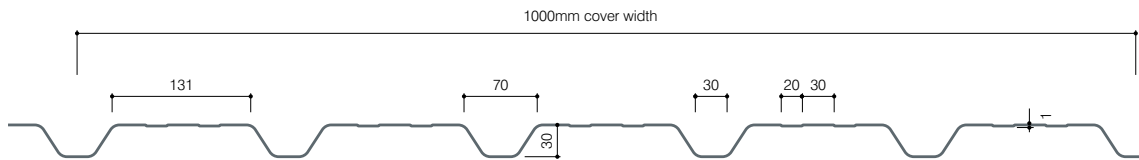

AS30/1000W steel wall profile • Thickness 0.5mm • Weight 4.57 kg/m ²																	
Bottom flange in compression Moment capacity: 0.688 kNm/m Moment of inertia: 6.955 cm ⁴ /m						Bottom flange in tension Moment capacity: 0.782 kNm/m Moment of inertia: 6.555 cm ⁴ /m						Support width: 40mm Web crushing: 8.054 kN/m Youngs modulus E: 210 kN/mm ²					
Positive Working load UDL (kN/m ²) Deflection limit L/90																	
Span / m	1.20	1.30	1.40	1.50	1.60	1.70	1.80	1.90	2.00	2.10	2.20	2.30	2.40	2.50	2.60	2.70	2.80
Single	2.90	2.47	2.13	1.85	1.63	1.44	1.29	1.16	1.04	0.95	0.86	0.79	0.72	0.67	0.62	0.57	0.53
Double	1.86	1.64	1.45	1.30	1.17	1.06	0.96	0.88	0.80	0.74	0.68	0.63	0.59	0.55	0.51	0.48	0.45
Multiple	2.23	1.97	1.75	1.57	1.41	1.28	1.16	1.06	0.98	0.90	0.83	0.77	0.72	0.67	0.62	0.58	0.55
Bottom flange in compression Moment capacity: 0.782 kNm/m Moment of inertia: 6.555 cm ⁴ /m						Bottom flange in tension Moment capacity: 0.688 kNm/m Moment of inertia: 6.955 cm ⁴ /m						Support width: 40mm Web crushing: 8.054 kN/m Young modulus: 210 kN/mm ²					
Negative Working load UDL (kN/m ²) Deflection limit L/90																	
Span / m	1.20	1.30	1.40	1.50	1.60	1.70	1.80	1.90	2.00	2.10	2.20	2.30	2.40	2.50	2.60	2.70	2.80
Single	2.55	2.17	1.87	1.63	1.43	1.27	1.13	1.02	0.92	0.83	0.76	0.69	0.64	0.59	0.54	0.50	0.47
Double	2.00	1.77	1.57	1.41	1.27	1.15	1.05	0.96	0.88	0.81	0.75	0.69	0.64	0.60	0.56	0.53	0.49
Multiple	2.39	2.12	1.89	1.69	1.53	1.38	1.26	1.16	1.06	0.98	0.91	0.84	0.78	0.73	0.68	0.64	0.60

AS30/1000W steel wall profile • Thickness 0.7mm • Weight 6.49 kg/m ²																	
Bottom flange in compression Moment capacity: 1.152 kNm/m Moment of inertia: 11.336 cm ⁴ /m						Bottom flange in tension Moment capacity: 1.182 kNm/m Moment of inertia: 10.711 cm ⁴ /m						Support width: 40mm Web crushing: 16.312 kN/m Youngs modulus E: 210 kN/mm ²					
Positive Working load UDL (kN/m ²) Deflection limit L/90																	
Span / m	1.20	1.30	1.40	1.50	1.60	1.70	1.80	1.90	2.00	2.10	2.20	2.30	2.40	2.50	2.60	2.70	2.80
Single	4.38	3.73	3.22	2.80	2.46	2.18	1.95	1.75	1.58	1.43	1.30	1.19	1.09	1.01	0.93	0.86	0.80
Double	3.36	2.94	2.60	2.32	2.08	1.88	1.70	1.55	1.42	1.30	1.20	1.11	1.03	0.96	0.89	0.84	0.78
Multiple	4.05	3.56	3.15	2.81	2.52	2.28	2.07	1.89	1.73	1.59	1.47	1.36	1.26	1.17	1.09	1.02	0.96
Bottom flange in compression Moment capacity: 1.182 kNm/m Moment of inertia: 10.711 cm ⁴ /m						Bottom flange in tension Moment capacity: 1.152 kNm/m Moment of inertia: 11.336 cm ⁴ /m						Support width: 40mm Web crushing: 16.312 kN/m Youngs modulus E: 210 kN/mm ²					
Negative Working load UDL (kN/m ²) Deflection limit L/90																	
Span / m	1.20	1.30	1.40	1.50	1.60	1.70	1.80	1.90	2.00	2.10	2.20	2.30	2.40	2.50	2.60	2.70	2.80
Single	4.27	3.64	3.13	2.73	2.40	2.13	1.90	1.70	1.54	1.39	1.27	1.16	1.07	0.98	0.91	0.84	0.78
Double	3.41	2.99	2.65	2.36	2.12	1.91	1.73	1.58	1.45	1.33	1.22	1.13	1.05	0.98	0.91	0.85	0.80
Multiple	4.11	3.61	3.20	2.86	2.57	2.32	2.11	1.92	1.76	1.62	1.49	1.38	1.28	1.19	1.12	1.04	0.98

BS EN 1991-1-4:

Appendix C.5.6.4: Partial safety factors for limit state design.
Load factors included within the load/span tables:

- Variable loads factor 1.5
- Permanent load factor 1.35
- Accidental load factor 1.0
- Serviceability load factor 1.0

Deflection

- Roofs - imposed loads - L/200
- Roofs - wind L/90
- Walls - wind L/90

AS SERIES ROOF & WALL PROFILES

AS35/1000 roof profile

A deep profile sheet which matches the AS35 insulated panel.
Available in 0.5 and 0.7mm thicknesses.

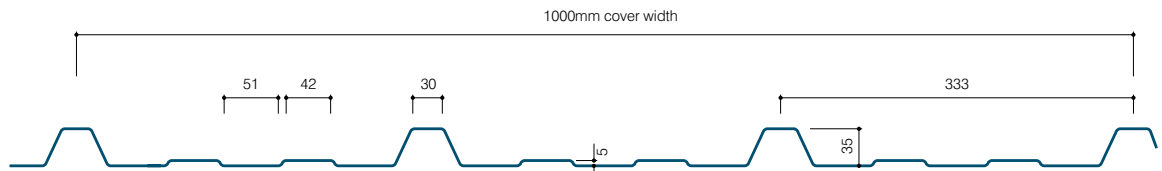

AS35/1000 steel roof profile • Thickness 0.5mm • Weight 4.57 kg/m

Bottom flange in compression Moment capacity: 0.471 kNm/m Moment of inertia: 5.305 cm ⁴ /m		Bottom flange in tension Moment capacity: 0.426 kNm/m Moment of inertia: 5.443 cm ⁴ /m		Support width: 40mm Web crushing: 4.200 kN/m Youngs modulus E: 210 kN/mm ²															
Imposed load	Working load UDL (kN/m ²) Deflection limit L/200																		
Span / m	1.20	1.30	1.40	1.50	1.60	1.70	1.80	1.90	2.00	2.10	2.20	2.30	2.40	2.50	2.60	2.70	2.80		
Single	1.58	1.34	1.16	1.01	0.89	0.79	0.70	0.63	0.57	0.50	0.43	0.38	0.33	0.30	0.26	0.23	0.21		
Double	1.13	1.00	0.89	0.80	0.72	0.65	0.60	0.55	0.50	0.46	0.43	0.40	0.37	0.35	0.32	0.30	0.29		
Multiple	1.34	1.19	1.06	0.96	0.87	0.79	0.72	0.66	0.61	0.56	0.52	0.48	0.45	0.42	0.39	0.37	0.35		
Bottom flange in compression Moment capacity: 0.426 kNm/m Moment of inertia: 5.443 cm ⁴ /m		Bottom flange in tension Moment capacity: 0.471 kNm/m Moment of inertia: 5.305 cm ⁴ /m		Support width: 40mm Web crushing: 4.200 kN/m Youngs modulus E: 210 kN/mm ²															
Wind uplift load	Working load UDL (kN/m ²) Deflection limit L/90																		
Span / m	1.20	1.30	1.40	1.50	1.60	1.70	1.80	1.90	2.00	2.10	2.20	2.30	2.40	2.50	2.60	2.70	2.80		
Single	1.74	1.49	1.28	1.12	0.98	0.87	0.78	0.70	0.63	0.57	0.52	0.47	0.44	0.40	0.37	0.34	0.32		
Double	1.07	0.94	0.84	0.75	0.68	0.62	0.56	0.51	0.47	0.43	0.40	0.37	0.35	0.32	0.30	0.28	0.27		
Multiple	1.28	1.13	1.01	0.90	0.82	0.74	0.68	0.62	0.57	0.53	0.49	0.45	0.42	0.39	0.37	0.34	0.32		
Bottom flange in compression Moment capacity: 0.471 kNm/m Moment of inertia: 5.305 cm ⁴ /m		Bottom flange in tension Moment capacity: 0.426 kNm/m Moment of inertia: 5.443 cm ⁴ /m		Support width: 40mm Web crushing: 4.200 kN/m Youngs modulus E: 210 kN/mm ²															
Snow drift load	Working load UDL (kN/m ²) Deflection limit L/200																		
Span / m	1.20	1.30	1.40	1.50	1.60	1.70	1.80	1.90	2.00	2.10	2.20	2.30	2.40	2.50	2.60	2.70	2.80		
Single	2.37	2.02	1.74	1.51	1.33	1.18	1.05	0.94	0.85	0.77	0.70	0.64	0.59	0.55	0.50	0.47	0.43		
Double	1.69	1.50	1.33	1.20	1.08	0.98	0.90	0.82	0.75	0.70	0.64	0.60	0.56	0.52	0.49	0.46	0.43		
Multiple	2.02	1.79	1.60	1.44	1.30	1.18	1.08	0.99	0.91	0.84	0.78	0.72	0.68	0.63	0.59	0.55	0.52		

AS35/1000 steel roof profile • Thickness 0.7mm • Weight 6.49 kg/m²

Bottom flange in compression Moment capacity: 0.709 kNm/m Moment of inertia: 8.320 cm ⁴ /m		Bottom flange in tension Moment capacity: 0.707 kNm/m Moment of inertia: 8.892 cm ⁴ /m		Support width: 40mm Web crushing: 8.506 kN/m Youngs modulus E: 210 kN/mm ²															
Imposed load	Working load UDL (kN/m ²) Deflection limit L/200																		
Span / m	1.20	1.30	1.40	1.50	1.60	1.70	1.80	1.90	2.00	2.10	2.20	2.30	2.40	2.50	2.60	2.70	2.80		
Single	2.62	2.23	1.92	1.68	1.47	1.30	1.16	1.04	0.91	0.78	0.68	0.60	0.53	0.46	0.41	0.37	0.33		
Double	1.94	1.70	1.51	1.35	1.21	1.10	1.00	0.91	0.83	0.77	0.71	0.66	0.61	0.57	0.53	0.50	0.46		
Multiple	2.33	2.05	1.82	1.63	1.47	1.33	1.21	1.10	1.01	0.93	0.86	0.80	0.74	0.69	0.65	0.61	0.55		
Bottom flange in compression Moment capacity: 0.707 kNm/m Moment of inertia: 8.892 cm ⁴ /m		Bottom flange in tension Moment capacity: 0.709 kNm/m Moment of inertia: 8.320 cm ⁴ /m		Support width: 40mm Web crushing: 8.506 kN/m Youngs modulus E: 210 kN/mm ²															
Wind uplift load	Working load UDL (kN/m ²) Deflection limit L/90																		
Span / m	1.20	1.30	1.40	1.50	1.60	1.70	1.80	1.90	2.00	2.10	2.20	2.30	2.40	2.50	2.60	2.70	2.80		
Single	2.63	2.24	1.93	1.68	1.48	1.31	1.17	1.05	0.95	0.86	0.78	0.71	0.66	0.61	0.56	0.52	0.48		
Double	1.93	1.70	1.51	1.35	1.21	1.10	1.00	0.91	0.83	0.77	0.71	0.65	0.61	0.57	0.53	0.49	0.46		
Multiple	2.32	2.05	1.82	1.63	1.46	1.33	1.21	1.10	1.01	0.93	0.86	0.80	0.74	0.69	0.64	0.60	0.57		
Bottom flange in compression Moment capacity: 0.709 kNm/m Moment of inertia: 8.320 cm ⁴ /m		Bottom flange in tension Moment capacity: 0.707 kNm/m Moment of inertia: 8.892 cm ⁴ /m		Support width: 40mm Web crushing: 8.506 kN/m Youngs modulus E: 210 kN/mm ²															
Snow drift load	Working load UDL (kN/m ²) Deflection limit L/200																		
Span / m	1.20	1.30	1.40	1.50	1.60	1.70	1.80	1.90	2.00	2.10	2.20	2.30	2.40	2.50	2.60	2.70	2.80		
Single	3.93	3.35	2.89	2.51	2.21	1.96	1.75	1.57	1.41	1.28	1.17	1.07	0.98	0.90	0.84	0.78	0.72		
Double	2.91	2.56	2.27	2.03	1.82	1.65	1.50	1.37	1.25	1.15	1.06	0.98	0.91	0.85	0.79	0.74	0.70		
Multiple	3.49	3.08	2.73	2.44	2.20	1.99	1.81	1.66	1.52	1.40	1.29	1.20	1.11	1.04	0.97	0.91	0.85		

Bold type: Spans between 1.20 -1.80m Non-fragile **Normal type:** Spans above 1.80m Fragile

AS SERIES ROOF & WALL PROFILES

AS35/1000 wall profile

A deep profile sheet which matches the AS35 insulated panel.

Available in 0.5 and 0.7mm thicknesses. AS35/1000 can also be used as a roof profile (see page 9 for load span tables).

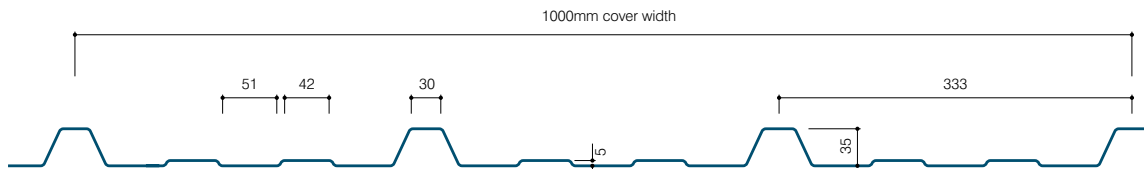

AS35/1000 steel wall profile • Thickness 0.5mm • Weight 4.57 kg/m²

Bottom flange in compression Moment capacity: 0.851 kNm/m Moment of inertia: 10.886 cm ⁴ /m		Bottom flange in tension Moment capacity: 0.942 kNm/m Moment of inertia: 10.609 cm ⁴ /m		Support width: 40mm Web crushing: 8.399 kN/m Youngs modulus E: 210 kN/mm ²													
Positive	Working load UDL (kN/m ²) Deflection limit L/90																
Span / m	1.20	1.30	1.40	1.50	1.60	1.70	1.80	1.90	2.00	2.10	2.20	2.30	2.40	2.50	2.60	2.70	2.80
Single	3.49	2.97	2.56	2.23	1.96	1.74	1.55	1.39	1.26	1.14	1.04	0.95	0.87	0.80	0.74	0.69	0.64
Double	2.14	1.89	1.68	1.50	1.36	1.23	1.12	1.02	0.94	0.87	0.80	0.74	0.69	0.65	0.60	0.57	0.53
Multiple	2.55	2.26	2.01	1.81	1.63	1.48	1.35	1.24	1.14	1.05	0.97	0.90	0.84	0.78	0.73	0.69	0.65
Bottom flange in compression Moment capacity: 0.942 kNm/m Moment of inertia: 10.609 cm ⁴ /m		Bottom flange in tension Moment capacity: 0.851 kNm/m Moment of inertia: 10.886 cm ⁴ /m		Support width: 40mm Web crushing: 8.399 kN/m Young modulus: 210 kN/mm ²													
Negative	Working load UDL (kN/m ²) Deflection limit L/90																
Span / m	1.20	1.30	1.40	1.50	1.60	1.70	1.80	1.90	2.00	2.10	2.20	2.30	2.40	2.50	2.60	2.70	2.80
Single	3.15	2.69	2.32	2.02	1.77	1.57	1.40	1.26	1.13	1.03	0.94	0.86	0.79	0.73	0.67	0.62	0.58
Double	2.25	1.99	1.78	1.60	1.44	1.31	1.19	1.09	1.01	0.93	0.86	0.80	0.74	0.69	0.65	0.61	0.57
Multiple	2.69	2.38	2.13	1.91	1.73	1.57	1.44	1.32	1.21	1.12	1.04	0.97	0.90	0.84	0.79	0.74	0.70

AS35/1000 steel wall profile • Thickness 0.7mm • Weight 6.49 kg/m²

Bottom flange in compression Moment capacity: 1.414 kNm/m Moment of inertia: 17.784 cm ⁴ /m		Bottom flange in tension Moment capacity: 1.418 kNm/m Moment of inertia: 16.640 cm ⁴ /m		Support width: 40mm Web crushing: 17.012 kN/m Youngs modulus E: 210 kN/mm ²													
Positive	Working load UDL (kN/m ²) Deflection limit L/90																
Span / m	1.20	1.30	1.40	1.50	1.60	1.70	1.80	1.90	2.00	2.10	2.20	2.30	2.40	2.50	2.60	2.70	2.80
Single	5.25	4.47	3.86	3.36	2.95	2.62	2.33	2.09	1.89	1.71	1.56	1.43	1.31	1.21	1.12	1.04	0.96
Double	3.87	3.40	3.02	2.70	2.42	2.19	1.99	1.82	1.66	1.53	1.41	1.31	1.22	1.13	1.06	0.99	0.93
Multiple	4.64	4.09	3.64	3.25	2.93	2.65	2.41	2.20	2.02	1.86	1.72	1.59	1.48	1.38	1.29	1.21	1.13
Bottom flange in compression Moment capacity: 1.418 kNm/m Moment of inertia: 16.640 cm ⁴ /m		Bottom flange in tension Moment capacity: 1.414 kNm/m Moment of inertia: 17.784 cm ⁴ /m		Support width: 40mm Web crushing: 17.012 kN/m Youngs modulus E: 210 kN/mm ²													
Negative	Working load UDL (kN/m ²) Deflection limit L/90																
Span / m	1.20	1.30	1.40	1.50	1.60	1.70	1.80	1.90	2.00	2.10	2.20	2.30	2.40	2.50	2.60	2.70	2.80
Single	5.24	4.46	3.85	3.35	2.95	2.61	2.33	2.09	1.89	1.71	1.56	1.43	1.31	1.21	1.12	1.03	0.96
Double	3.87	3.41	3.02	2.70	2.43	2.19	1.99	1.82	1.67	1.53	1.42	1.31	1.22	1.13	1.06	0.99	0.93
Multiple	4.65	4.10	3.64	3.26	2.93	2.66	2.42	2.21	2.03	1.87	1.72	1.60	1.48	1.38	1.29	1.21	1.14

BS EN 1991-1-4:

Appendix C.5.6.4: Partial safety factors for limit state design.

Load factors included within the load/span tables:

- Variable loads factor 1.5
- Permanent load factor 1.35
- Accidental load factor 1.0
- Serviceability load factor 1.0

Deflection

- Roofs - imposed loads - L/200
- Roofs - wind L/90
- Walls - wind L/90

AS SERIES ROOF & WALL PROFILES

AS13/3/990 S roof profile

Shallow corrugated profile sheet available in 0.5mm and 0.7mm thicknesses.

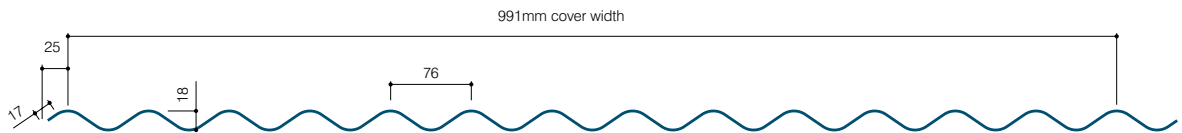

AS13/3/900 S steel roof profile • Thickness 0.5mm • Weight 4.57 kg/m²

Bottom flange in compression Moment capacity: 0.433 kNm/m Moment of inertia: 1.770 cm ⁴ /m		Bottom flange in tension Moment capacity: 0.433 kNm/m Moment of inertia: 1.770 cm ⁴ /m		Support width: 40mm Web crushing: 7.87 kN/m Youngs modulus E: 210 kN/mm ²													
Imposed load	Working load UDL (kN/m ²) Deflection limit L/200																
Span / m	1.20	1.30	1.40	1.50	1.60	1.70	1.80	1.90	2.00	2.10	2.20	2.30	2.40	2.50	2.60	2.70	2.80
Single	0.83	0.65	0.52	0.42	0.35	0.29	0.24	0.21	0.18	0.15	0.13	0.12	0.10	0.09	0.08	0.07	0.07
Double	1.37	1.08	0.87	0.70	0.58	0.48	0.41	0.35	0.30	0.26	0.22	0.20	0.17	0.15	0.14	0.12	0.11
Multiple	1.38	1.08	0.87	0.70	0.58	0.48	0.41	0.35	0.30	0.26	0.22	0.20	0.17	0.15	0.14	0.12	0.11
Bottom flange in compression Moment capacity: 0.433 kNm/m Moment of inertia: 1.770 cm ⁴ /m		Bottom flange in tension Moment capacity: 0.433 kNm/m Moment of inertia: 1.770 cm ⁴ /m		Support width: 40mm Web crushing: 7.87 kN/m Youngs modulus E: 210 kN/mm ²													
Wind uplift load	Working load UDL (kN/m ²) Deflection limit L/90																
Span / m	1.20	1.30	1.40	1.50	1.60	1.70	1.80	1.90	2.00	2.10	2.20	2.30	2.40	2.50	2.60	2.70	2.80
Single	1.60	1.37	1.16	0.94	0.77	0.65	0.54	0.46	0.40	0.34	0.30	0.26	0.23	0.20	0.18	0.16	0.14
Double	1.37	1.20	1.06	0.94	0.84	0.75	0.68	0.62	0.57	0.52	0.48	0.43	0.38	0.34	0.30	0.27	0.24
Multiple	1.67	1.46	1.29	1.14	1.02	0.92	0.83	0.76	0.66	0.57	0.50	0.43	0.38	0.34	0.30	0.27	0.24
Bottom flange in compression Moment capacity: 0.433 kNm/m Moment of inertia: 1.770 cm ⁴ /m		Bottom flange in tension Moment capacity: 0.433 kNm/m Moment of inertia: 1.770 cm ⁴ /m		Support width: 40mm Web crushing: 7.87 kN/m Youngs modulus E: 210 kN/mm ²													
Snow drift load	Working load UDL (kN/m ²) Deflection limit L/200																
Span / m	1.20	1.30	1.40	1.50	1.60	1.70	1.80	1.90	2.00	2.10	2.20	2.30	2.40	2.50	2.60	2.70	2.80
Single	2.41	2.05	1.77	1.54	1.35	1.20	1.07	0.96	0.87	0.79	0.72	0.65	0.60	0.55	0.51	0.48	0.44
Double	2.06	1.80	1.59	1.41	1.26	1.13	1.02	0.93	0.85	0.78	0.72	0.65	0.60	0.55	0.51	0.48	0.44
Multiple	2.50	2.19	1.93	1.71	1.53	1.38	1.25	1.14	1.04	0.95	0.88	0.81	0.75	0.69	0.64	0.59	0.55

AS13//900 S steel roof profile • Thickness 0.7mm • Weight 6.49 kg/m²

Bottom flange in compression Moment capacity: 0.618 kNm/m Moment of inertia: 2.529 cm ⁴ /m		Bottom flange in tension Moment capacity: 0.618 kNm/m Moment of inertia: 2.529 cm ⁴ /m		Support width: 40mm Web crushing: 19.827 kN/m Youngs modulus E: 210 kN/mm ²													
Imposed load	Working load UDL (kN/m ²) Deflection limit L/200																
Span / m	1.20	1.30	1.40	1.50	1.60	1.70	1.80	1.90	2.00	2.10	2.20	2.30	2.40	2.50	2.60	2.70	2.80
Single	1.18	0.93	0.74	0.60	0.50	0.42	0.35	0.30	0.25	0.22	0.19	0.17	0.15	0.13	0.12	0.10	0.09
Double	1.97	1.55	1.24	1.01	0.83	0.69	0.58	0.50	0.42	0.37	0.32	0.28	0.25	0.22	0.19	0.17	0.15
Multiple	1.97	1.55	1.24	1.01	0.83	0.69	0.58	0.50	0.42	0.37	0.32	0.28	0.25	0.22	0.19	0.17	0.15
Bottom flange in compression Moment capacity: 0.618 kNm/m Moment of inertia: 2.529 cm ⁴ /m		Bottom flange in tension Moment capacity: 0.618 kNm/m Moment of inertia: 2.529 cm ⁴ /m		Support width: 40mm Web crushing: 19.827 kN/m Youngs modulus E: 210 kN/mm ²													
Wind uplift load	Working load UDL (kN/m ²) Deflection limit L/90																
Span / m	1.20	1.30	1.40	1.50	1.60	1.70	1.80	1.90	2.00	2.10	2.20	2.30	2.40	2.50	2.60	2.70	2.80
Single	2.29	1.95	1.65	1.34	1.11	0.92	0.78	0.66	0.57	0.49	0.43	0.37	0.33	0.29	0.26	0.23	0.21
Double	2.27	1.95	1.68	1.46	1.29	1.14	1.02	0.91	0.82	0.75	0.68	0.62	0.55	0.48	0.43	0.38	0.34
Multiple	2.78	2.41	2.10	1.83	1.61	1.43	1.27	1.10	0.94	0.82	0.71	0.62	0.55	0.48	0.43	0.38	0.34
Bottom flange in compression Moment capacity: 0.618 kNm/m Moment of inertia: 2.529 cm ⁴ /m		Bottom flange in tension Moment capacity: 0.618 kNm/m Moment of inertia: 2.529 cm ⁴ /m		Support width: 40mm Web crushing: 19.827 kN/m Youngs modulus E: 210 kN/mm ²													
Snow drift load	Working load UDL (kN/m ²) Deflection limit L/200																
Span / m	1.20	1.30	1.40	1.50	1.60	1.70	1.80	1.90	2.00	2.10	2.20	2.30	2.40	2.50	2.60	2.70	2.80
Single	3.43	2.93	2.52	2.20	1.93	1.71	1.53	1.37	1.24	1.12	1.02	0.93	0.86	0.79	0.73	0.68	0.63
Double	3.41	2.93	2.52	2.20	1.93	1.71	1.53	1.37	1.24	1.12	1.02	0.93	0.86	0.79	0.73	0.68	0.63
Multiple	4.17	3.62	3.15	2.75	2.41	2.14	1.91	1.71	1.55	1.40	1.28	1.17	1.07	0.99	0.91	0.85	0.79

Bold type: Spans between 1.20 -1.80m Non-fragile **Normal type:** Spans above 1.80m Fragile

AS SERIES ROOF & WALL PROFILES

AS13/3/990 S wall profile

A shallow corrugated profile sheet available in 0.5mm and 0.7mm thicknesses.

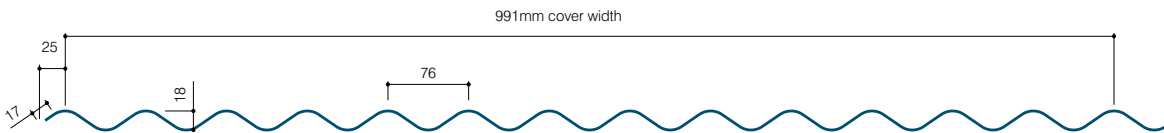

AS13/3/900 S steel wall profile • Thickness 0.5mm • Weight 4.57 kg/m²

Bottom flange in compression Moment capacity: 0.433 kNm/m Moment of inertia: 1.770 cm ⁴ /m		Bottom flange in tension Moment capacity: 0.433 kNm/m Moment of inertia: 1.770 cm ⁴ /m		Support width: 40mm Web crushing: 7.870 kN/m Youngs modulus E: 210 kN/mm ²													
Positive		Working load UDL (kN/m ²) Deflection limit L/90															
Span / m	1.20	1.30	1.40	1.50	1.60	1.70	1.80	1.90	2.00	2.10	2.20	2.30	2.40	2.50	2.60	2.70	2.80
Single	1.60	1.37	1.16	0.94	0.77	0.65	0.54	0.46	0.40	0.34	0.30	0.26	0.23	0.20	0.18	0.16	0.14
Double	1.37	1.20	1.06	0.94	0.84	0.75	0.68	0.62	0.57	0.52	0.48	0.43	0.38	0.34	0.30	0.27	0.24
Multiple	1.67	1.46	1.29	1.14	1.02	0.92	0.83	0.76	0.66	0.57	0.50	0.43	0.38	0.34	0.30	0.27	0.24
Bottom flange in compression Moment capacity: 0.433 kNm/m Moment of inertia: 1.770 cm ⁴ /m		Bottom flange in tension Moment capacity: 0.433 kNm/m Moment of inertia: 1.770 cm ⁴ /m		Support width: 40mm Web crushing: 7.870 kN/m Young modulus: 210 kN/mm ²													
Negative		Working load UDL (kN/m ²) Deflection limit L/90															
Span / m	1.20	1.30	1.40	1.50	1.60	1.70	1.80	1.90	2.00	2.10	2.20	2.30	2.40	2.50	2.60	2.70	2.80
Single	1.60	1.37	1.16	0.94	0.77	0.65	0.54	0.46	0.40	0.34	0.30	0.26	0.23	0.20	0.18	0.16	0.14
Double	1.37	1.20	1.06	0.94	0.84	0.75	0.68	0.62	0.57	0.52	0.48	0.43	0.38	0.34	0.30	0.27	0.24
Multiple	1.67	1.46	1.29	1.14	1.02	0.92	0.83	0.76	0.66	0.57	0.50	0.43	0.38	0.34	0.30	0.27	0.24

AS13/3/900 S steel wall profile • Thickness 0.7mm • Weight 6.49 kg/m²

Bottom flange in compression Moment capacity: 0.618 kNm/m Moment of inertia: 2.529 cm ⁴ /m		Bottom flange in tension Moment capacity: 0.618 kNm/m Moment of inertia: 2.529 cm ⁴ /m		Support width: 40mm Web crushing: 19.827 kN/m Youngs modulus E: 210 kN/mm ²													
Positive		Working load UDL (kN/m ²) Deflection limit L/90															
Span / m	1.20	1.30	1.40	1.50	1.60	1.70	1.80	1.90	2.00	2.10	2.20	2.30	2.40	2.50	2.60	2.70	2.80
Single	2.29	1.95	1.65	1.34	1.11	0.92	0.78	0.66	0.57	0.49	0.43	0.37	0.33	0.29	0.26	0.23	0.21
Double	2.27	1.95	1.68	1.46	1.29	1.14	1.02	0.91	0.82	0.75	0.68	0.62	0.55	0.48	0.43	0.38	0.34
Multiple	2.78	2.41	2.10	1.83	1.61	1.43	1.27	1.10	0.94	0.82	0.71	0.62	0.55	0.48	0.43	0.38	0.34
Bottom flange in compression Moment capacity: 0.618 kNm/m Moment of inertia: 2.529 cm ⁴ /m		Bottom flange in tension Moment capacity: 0.618 kNm/m Moment of inertia: 2.529 cm ⁴ /m		Support width: 40mm Web crushing: 19.827 kN/m Youngs modulus E: 210 kN/mm ²													
Negative		Working load UDL (kN/m ²) Deflection limit L/90															
Span / m	1.20	1.30	1.40	1.50	1.60	1.70	1.80	1.90	2.00	2.10	2.20	2.30	2.40	2.50	2.60	2.70	2.80
Single	2.29	1.95	1.65	1.34	1.11	0.92	0.78	0.66	0.57	0.49	0.43	0.37	0.33	0.29	0.26	0.23	0.21
Double	2.27	1.95	1.68	1.46	1.29	1.14	1.02	0.91	0.82	0.75	0.68	0.62	0.55	0.48	0.43	0.38	0.34
Multiple	2.78	2.41	2.10	1.83	1.61	1.43	1.27	1.10	0.94	0.82	0.71	0.62	0.55	0.48	0.43	0.38	0.34

BS EN 1991-1-4:

Appendix C.5.6.4: Partial safety factors for limit state design.
Load factors included within the load/span tables:

- Variable loads factor 1.5
- Permanent load factor 1.35
- Accidental load factor 1.0
- Serviceability load factor 1.0

Deflection

- Roofs - imposed loads - L/200
- Roofs - wind L/90
- Walls - wind L/90









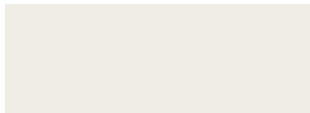

COLOUR AND PERFORMANCE

Colours

The table below shows available standard profile colours*. Special colours are also available on request.

The printed colours shown are for guidance only. For a true representation please ask us to send an actual metal swatch.

To ensure tonal consistency between components for a single contract, material should come from the same production batch and therefore should be placed as one order.

Plastisol durability group colours			
			
Goosewing Grey* 10A05	Ivory RAL9002	Merlin Grey* 18B25	Moorland Green 12B21
			
Mushroom 10B19	Olive Green 12B275	Juniper Green* 12B29	Ocean Blue 18C39
			
Slate Blue* 18B29	Terracotta* 04C395	Vandyke Brown* 08B29	White 00E55

*The colours include the nearest British Standard reference for guidance only as the colours may vary slightly.

Plastisol durability group colours	
Group 1:	Anthracite, Albatross, Bamboo, Buttermilk, Goosewing Grey, Ivory, Merlin Grey, Moorland Green, Mushroom, New Grey, Olive Green, Pigeon Grey, Wedgwood Blue, White, Willow.
Group 2:	Black, Cornflower Blue, Country Green, Forest Green, Golden Glow, Golden Yellow, Jade, Juniper Green, Linden Green, New Red, Ocean Blue, Pacific Blue, Poppy Red, Saffron, Sage Green, Slate Blue, Terracotta, Tangerine Orange, Vandyke Brown.

Plastisol life expectancy to first full repaint				
	Wall profiles		Roof profiles	
	Inland	Coastal**	Inland	Coastal**
Group 1	30	25	25	20
Group 2	25	20	20	15

**Within 2km from the sea

Subject to available colour options.

For extended coatings up to 40 years please contact the Steadmans Sales Office for more details.

Plastisol durability group colours		
Weather sheet	200LG 200 micron	200 micron high performance pre-painted steel system on a hot dipped substrate. The outer face is finished with a leather-grain embossed PVC while the inner face is finished with a heat cured epoxy paint system.
	Dobel Nova	50 micron thick acrylic polymer coating which has high wear resistance, excellent colourfastness and good flexibility. The coating contains no PVC or Isocyanates and the material is wholly recyclable.
	Polyester	30 micron polyester coating with a medium term life.
	Agri-Steel	Double sided 35/35 micron polyester coating recommended for the agricultural market. Agri-Steel has a superior interior paint finish when compared to standard polyester.
	HPS200 Ultra	200 micron durable organic coating with Scintilla finish on a substrate treated with hot dipped zinc-aluminium alloy.
	PVDF	27 micron thick stoved fluorocarbon coating: excellent colour stability at temperatures as high as 120°C.

Note: Colorcoat HPS200 Ultra, is trademarks of Tata Steel UK Limited.

ACCESSORIES

Gutters

Steadmans manufacture and supply a range of gutters which can be produced from a variety of materials including pre-galvanised steel (to BS EN 10143:2006) and pre-coated steel, either painted or PVC-coated on one or both sides; aluminium gutters can be supplied to order if required.

Complete gutter systems and accessories can be manufactured to specification, up to 10m long and 3mm thick, subject to the gutter profile.

Flashings

Steadmans can manufacture flashings to match the colour of the single skin cladding in either Plastisol Leathergrain, polyester, Nova, galvanised, or PVDF finishes. Flashings can be supplied in lengths of up to 6m in traditional profiles, or gutters can be shaped to meet special customer requirements.

Sealants

Steadmans supply a range of NFRC Class A butyl sealants, profile foam fillers and expanding foams to enable the Steadmans single skin profiles to be sealed to each other and to other building components, to avoid water ingress and air leakage.



CONDENSATION

Dealing with Condensation

Uninsulated roofs with single-skin metal sheeting are likely to suffer from condensation when the metal sheeting is cooled during the winter, or on cold clear nights. When warm air within the building cools on contact with the cooler metal sheeting it can not support the same quantity of water vapour and may become saturated, with any excess water vapour condensing on the underside of the sheeting.

The condensatation can drip from the roof, wetting the building's fittings and/or contents, or may run down the roof and collect elsewhere within the building fabric where it can cause rust, rot or damage fittings.

Sealants

Part C2 of the Building Regulation requires designers to prevent harmful condensation forming on or within building elements. To minimise the risk of condensation designers should arrange for the extraction of moisture generated by activities and processes within the building and adopt forms of construction which will not trap moisture within building elements. Designers should observe the guidance in BS 5250:2011.

Designers should assess the risk of condensation using the method in BS EN 3788:2002 and the guidance in BS 5250:2011+A1:2016.

Alternative products for condensation control



AS35 Composite Panel

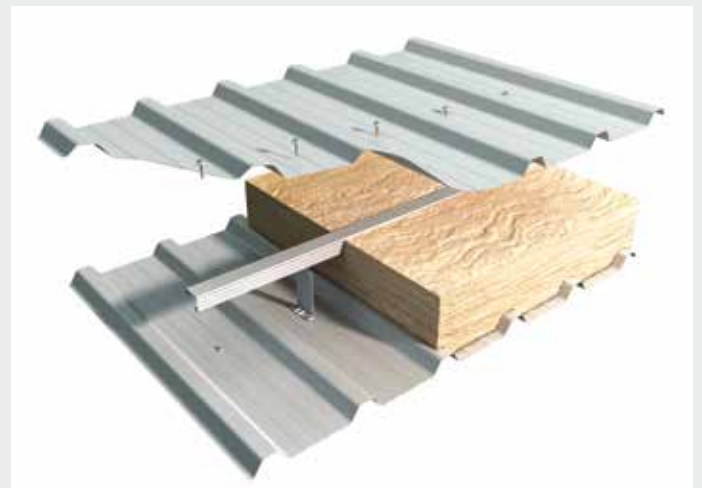

Gemello Twin Skin

Structure

Steadmans single skin sheets are designed to be supported by steel or timber purlins. Roof profiles are laid with the broad valley resting on the purlin: wall profiles will usually have the narrow valley against the side rail.

All 0.5 mm & 0.7mm thick trapezoidal profiles are suitable for spanning purlins at 1.8m centres. Consult the Steadmans' Technical Department for guidance on using the profiles on purlins centres greater than 1.8m. Steelwork for single skin systems should be within the tolerances given in BS EN 1090-2:2008+A1:2011 AS single skin sheets should be isolated from preservative treated timber purlins by PVC barrier tape applied to the bearing face of the purlins.

Fixings

Fixings for roof profiles provide restraint against wind uplift forces; those for wall profiles provide restraint and support. The profiles must be fixed through valleys of the profile, therefore accurate fixing is easier to achieve, loads on the fixings are smaller, the fixings are less likely to distort the profile, and better compression of the sealant is achieved at end laps.

Fixings should be stainless steel or carbon-steel self drilling screws, have press-on or integral caps to match the colour of the profile and a 19mm (roof) or 16mm (wall) diameter EDPM washer to prevent water penetration.

Fixings to light and heavy section steel should pass through the steel and leave 5mm of thread exposed on the underside of the section. Fixing to timber must achieve a minimum 40mm embedment.

AS24/1000 Wall Profile

AS24/1000 W: outer wall sheet: fixing guide -

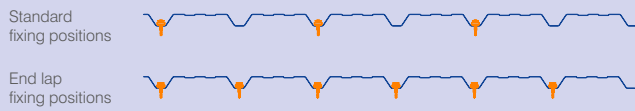

AS30/1000 Wall Profile

AS30/1000 W: outer wall sheet: fixing guide -

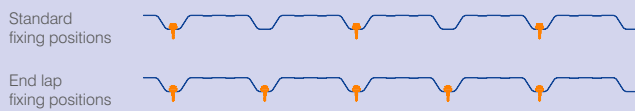

AS35/1000 Wall Profile

AS35/1000 W: outer wall sheet: fixing guide -

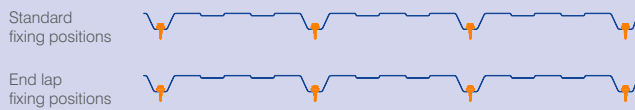

AS13/3/990 Wall Profile

AS13/3/990 W: outer wall sheet: fixing guide -

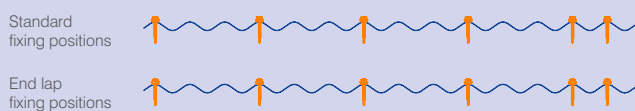

Weather sheets should be fixed directly to the purlins.

Consult Steadmans' Technical Department for guidance on fixing sheets in extreme exposure conditions.

The AS13/3/990 corrugated profiles should be fixed through the crowns of the corrugations. Profiles should be fixed at every second crown at each end (including laps). Stagger the fixing pattern across multiple intermediate purlins (there must be a fixing in each side lap).

AS24/1000 Roofing Profile

AS24/1000 W: outer roof sheet: fixing guide -

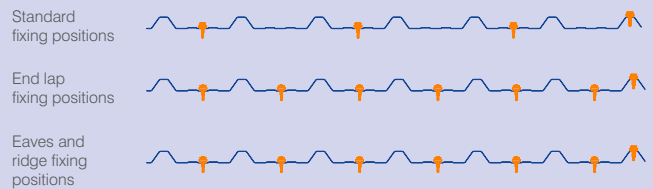

AS30/1000 Roofing Profile

AS30/1000 W: outer roof sheet: fixing guide -

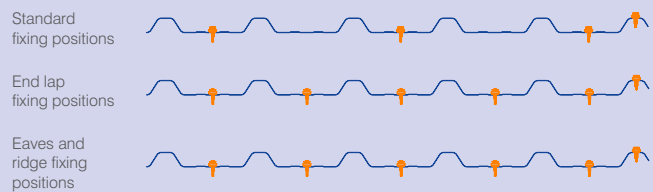

AS35/1000 Roofing Profile

AS35/1000 W: outer roof sheet: fixing guide -

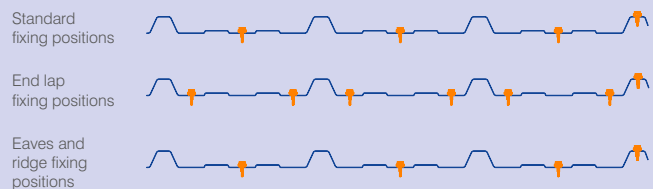

AS13/3/990 Roofing Profile

AS13/3/990 W: outer roof sheet: fixing guide -

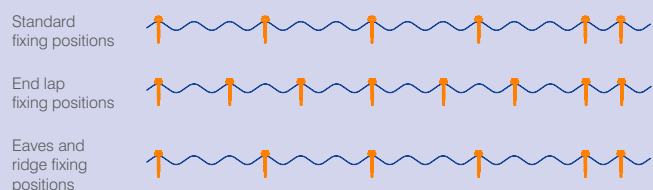

Laps

Side laps between sheets are formed by lapping the female side of one sheet over the male crown of the adjacent sheet. It is considered best practice that the exposed edge of the lap should face away from the prevailing wind.

The side laps of weather sheets should be sealed with butyl sealant strip 6x5mm high. Weather sheet side laps on roofs should be stitched with 23mm long self drilling screws at 450mm centres.

For wall applications, stitch at 500mm centres for vertical sheets and 600mm for horizontal sheets.

End laps are formed by lapping the upper weather sheet 150mm over the lower sheet. End laps of weather sheets should be sealed with two runs of butyl sealant strip 6x5mm high applied 10 -15mm from each end of the lap and fixed with 25mm fasteners.

Rooflights

Rooflights can be supplied to meet project requirements for light transmission, durability, non-fragility rating and fire resistance: contact Steadmans' sales office for details.

Illuminance: the area of rooflights required to illuminate the building interior depends upon the type of activities taking place. BS EN 17037:2018 Daylight In Buildings.

Solar gain: designers are required to ensure solar gains in summer will not be excessive. CIBSE document TM37 contains guidance and calculation methods.

Safety: rooflights must provide safety levels appropriate to the frequency of roof access. All Steadmans rooflights offer a non-fragility rating of class B on installation. However, for standard 2.4kg gauge rooflights that level of non-fragility may not be maintained over their 25 year service life. Where rooflights must be non-fragile throughout their service life Steadmans recommend the use of 3.0kg gauge rooflights. Consult Steadmans Technical Team for further guidance.

Figure 01:

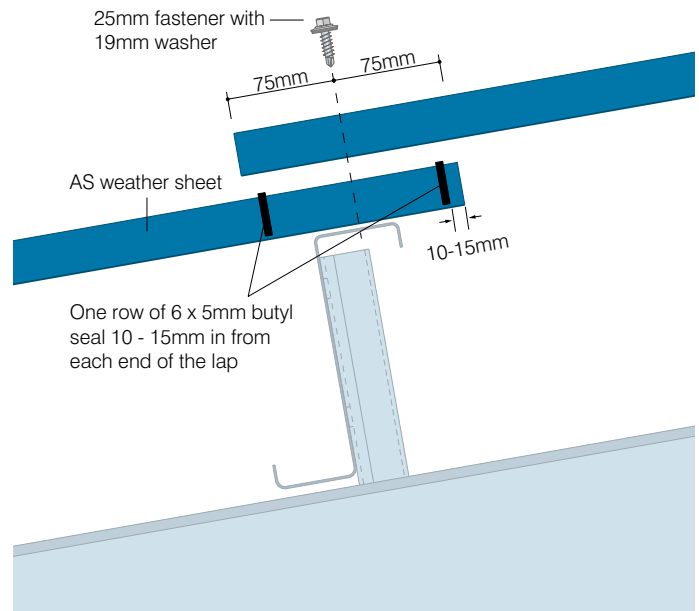
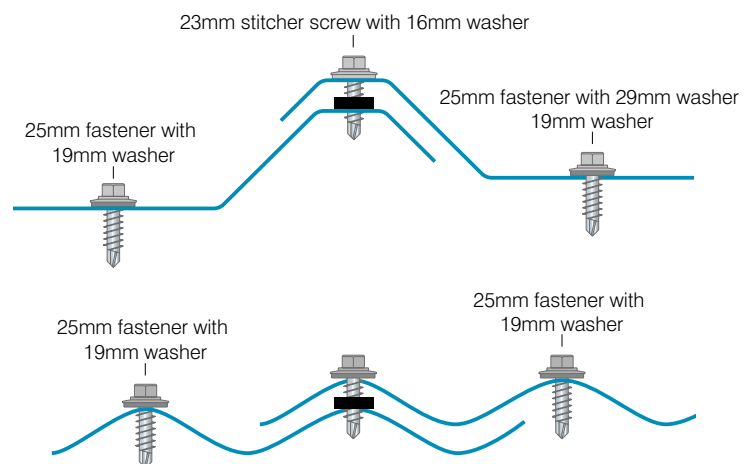

Figure 02: End lap fixing details – roof profiles (Sheeting laps)



Rooflight Laps

To comply with fragility requirement of the sheets the edge distances of all metal and GRP weather sheets should extend a minimum of 50mm beyond the fixing line.

Side laps between rooflights and the Steadmans weather sheets should be sealed with 6x5mm butyl sealant and stitched with 23mm self drilling fixings or laplocks. End laps should be sealed with two runs of 6x5mm UV stable pale coloured cross linked butyl mastic applied no more than 25mm from each end of the lap. Where four sheets overlap additional runs of butyl sealant are required between the male and female crowns of all four sheets. Rooflights can be lapped over the metal sheets on both sides to facilitate fixing if required.

Rooflights	
Property Value	Roof profiles
Minimum slope	6°
Maximum length	7m
Width (centre-centre)	1000mm
U-value	2.2* W/m ²

* Figures supplied by Brett Martin Daylight Systems Ltd. Other manufacturer's figures may vary

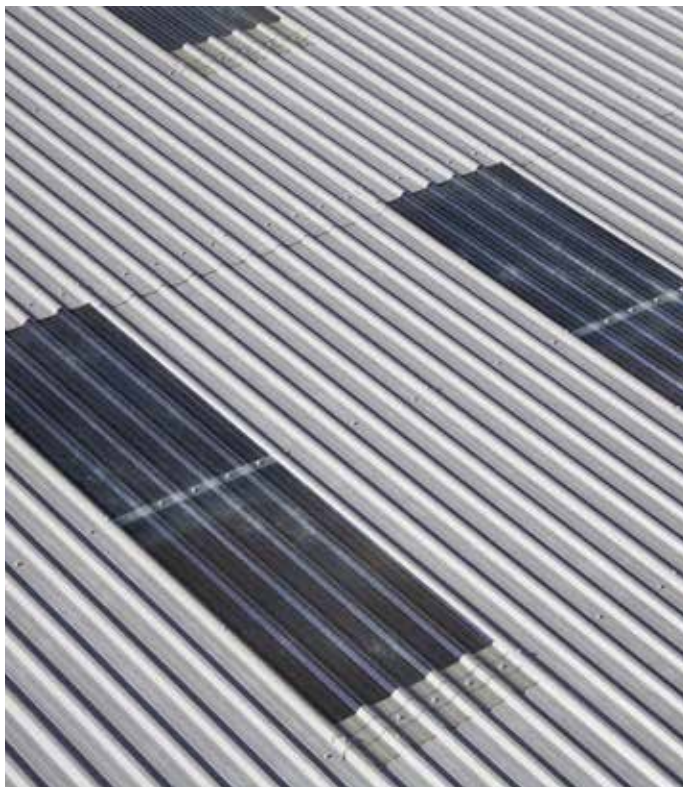

Fire:

The inner skin of a ceiling should normally be rated Class 1 (BS476 Part 7) or Class C-s3,d2 (BS EN 13501 Part 1).

For buildings with individual rooflights less than 5m² a concession* allows the inner skin of a rooflight to be rated Class 3 (BS476 Part 7) Class D-s3,d2 (BS EN 13501 Part 1).

*Also requires a clear space of 3 metres (1.8 metres in some applications) in all directions between each rooflight.

Figure 03: End lap fixing details – roof profiles (Rooflight laps)

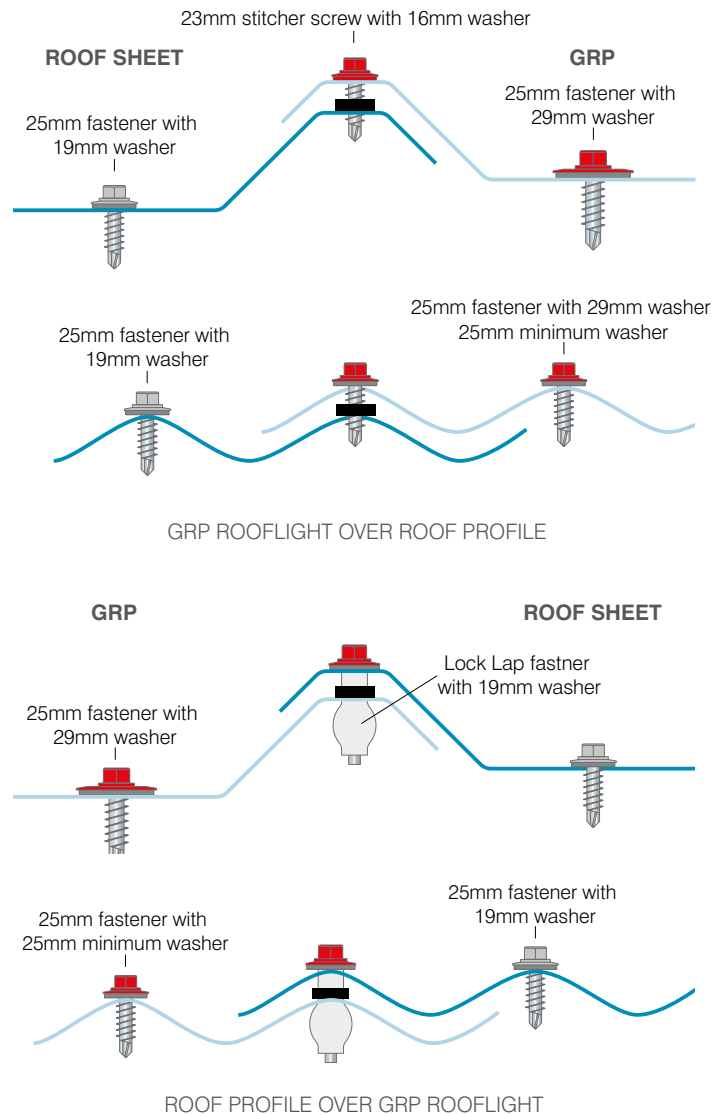

Handling and storage

Steadmans profiles are delivered to site in packs. Packing sheets are used at the top and bottom of the packs to provide protection and the ends of the packs are wrapped with plastic. Maximum pack weight is 2 tonne.

The packs can be off-loaded directly onto the roof, or to a storage area, which should be dry and well away from traffic. Packs may be stacked using suitable wooden bearers and packers. Bearers should be placed in line with each other in between the packs. Handle the cladding sheets carefully to avoid marking the weather sheets. Lift sheets from the pack –do not drag them. Observe site health and safety procedures at all times as well as the results of manual handling and other assessments carried out on site.

Preparation

Single skin roof and wall systems are designed to be supported by and fixed to steel purlins. Primary steelwork should be within the tolerances given in National Structural Steelwork Specification for Building Construction (NSSS) and BS EN 1090-2:2018. Secondary steelwork should be within the tolerances of SCI publication P346 “Best Practice for the Specification and Installation of Metal Cladding and Secondary Steelwork”. MCRMA Guidance documents GD 20 “Guidance document on serviceability states and deflection criteria”, GD 24 “Installation of purlins and side rails” and GD27 “Installed tolerances: best practice design guide” offer useful additional information.

Before fixing any sheets check the squareness and accuracy of the steelwork. Lay into the prevailing wind direction if possible so that laps face away from the wind direction.

Inspect packs and record any damage or shortages on the delivery paperwork. Report any damage or shortages to Steadmans, backed by photos, within 48 hours of delivery.





Walls – laying sequence

The following sequence applies to weather sheets on walls:

1. Set sheet one upright against the framing at the corner of the building with the female edge to the corner. Make sure the profile is vertical.
2. Fix with one fixing in alternate valleys at each rail.
3. Apply a run of butyl sealant along the male crown.
4. Set sheet two upright with its female edge lapping the male edge of sheet one.
5. Fix the sheet.
6. Stitch the lap with self-drilling fixings @ 600mm centres.
7. Continue to lay sheets along the wall, checking the alignment of the cladding and correcting any deviations.
8. Fix flashings. Use foam filler pieces and butyl sealant to form weather tight junctions.

Cutting profiles

Where profiles have to be cut on site:

- Use a powered nibbler, reciprocating saw or circular saw. Do not use an abrasive wheel.
- Support the profile along the line of the cut.
- Protect the pre-coated finishes of the profile.
- Clean any swarf or debris from the pre-coated finish of the profile immediately.

Completion

When all the sheets have been installed check:

- All fixings are correctly fitted and tightened.
- The fixings do not distort the profile.
- All fixing caps are fitted.
- Minor scratches have been treated.
- The surface of the roof is clean and free of any swarf or debris.

Roof Sheet Installation Guide

1. Side laps should ideally face away from the prevailing wind.
2. Establish the setting out dimension (should be indicated in the roof construction drawings).
3. Set out a line at 90 degrees to the gutter line.
4. Install eaves flashing.
5. Install eaves filler blocks, bedded in sealant top and bottom.
6. Install cladding sheets as shown in the diagram, working from eaves to ridge before installing the second tier. Lay sheets with the male rib leading.
7. Fully fix profiles as you proceed. Use fasteners with 19mm dia washers. Partial fixing/fly-fixing is dangerous.
8. End laps 150mm.
9. Install end lap 6x5mm Class A butyl sealants 10-15mm from sheet ends. Overlap any joins in sealant strips by 25mm.
10. Install side lap 6x5mm Class A butyl sealant to the weather side of the stitcher fasteners line.
11. 4-way lap detail: See diagram. Remembering the extra short strip of sealant on top of the 3rd sheet in the 4 way lap, to seal the gap where sealant is covered over.
12. Install stitcher fasteners at 450mm max spacing.
13. Install ridge filler blocks, bedded both sides in sealant.
14. Install ridge and verge flashings to the project specific construction drawing detail.
15. Ridge and verge flashings, 75mm laps (open sections) or 150mm butt straps (closed sections), as specified.
16. Fix ridge caps to every crown using stitcher screws.
17. Fix verge flashings to ribs or to mini zed spacers in turn fixed to the spacer bar, flashing fasteners at max 450mm centres.
18. Seal flashings with 6x5mm butyl sealant or gun applied butyl sealant, as specified. Apply sealant either side of the fasteners, 10–15mm from flashing edges.
19. Where profiles have to be cut on site:
 - Use a powered nibbler, reciprocating saw or circular saw. Do not use an abrasive wheel.
 - Support the profile along the line of the cut.
 - Protect the pre-coated finishes of the profile.
 - Clean any swarf or debris from the pre-coated finish of the profile immediately.
20. Minor scuffing of the colour coating should not be treated.
21. Deeper scratches which reach the substrate should be repaired with touch-up paint.

The touch-up paint should only be applied to the original scratch using a fine paint brush.

As touch-up paint will dry to a slightly different colour than the original coating the area which is touched up should be kept as small as possible.
22. Keep foot traffic and following trades traffic to a minimum.

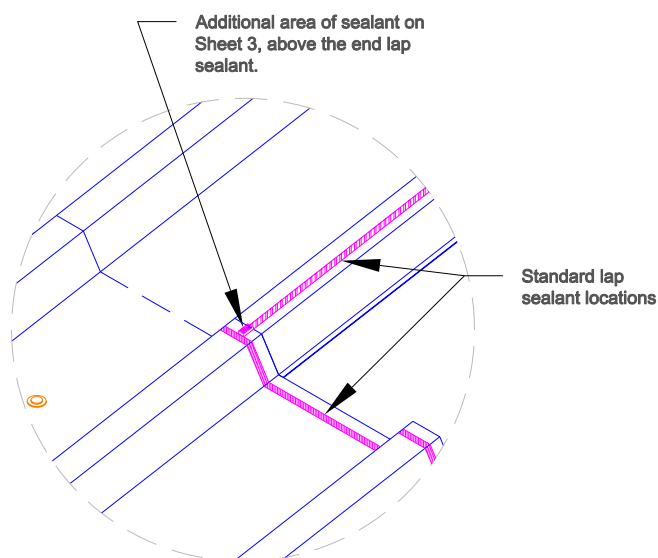

INSTALLATION

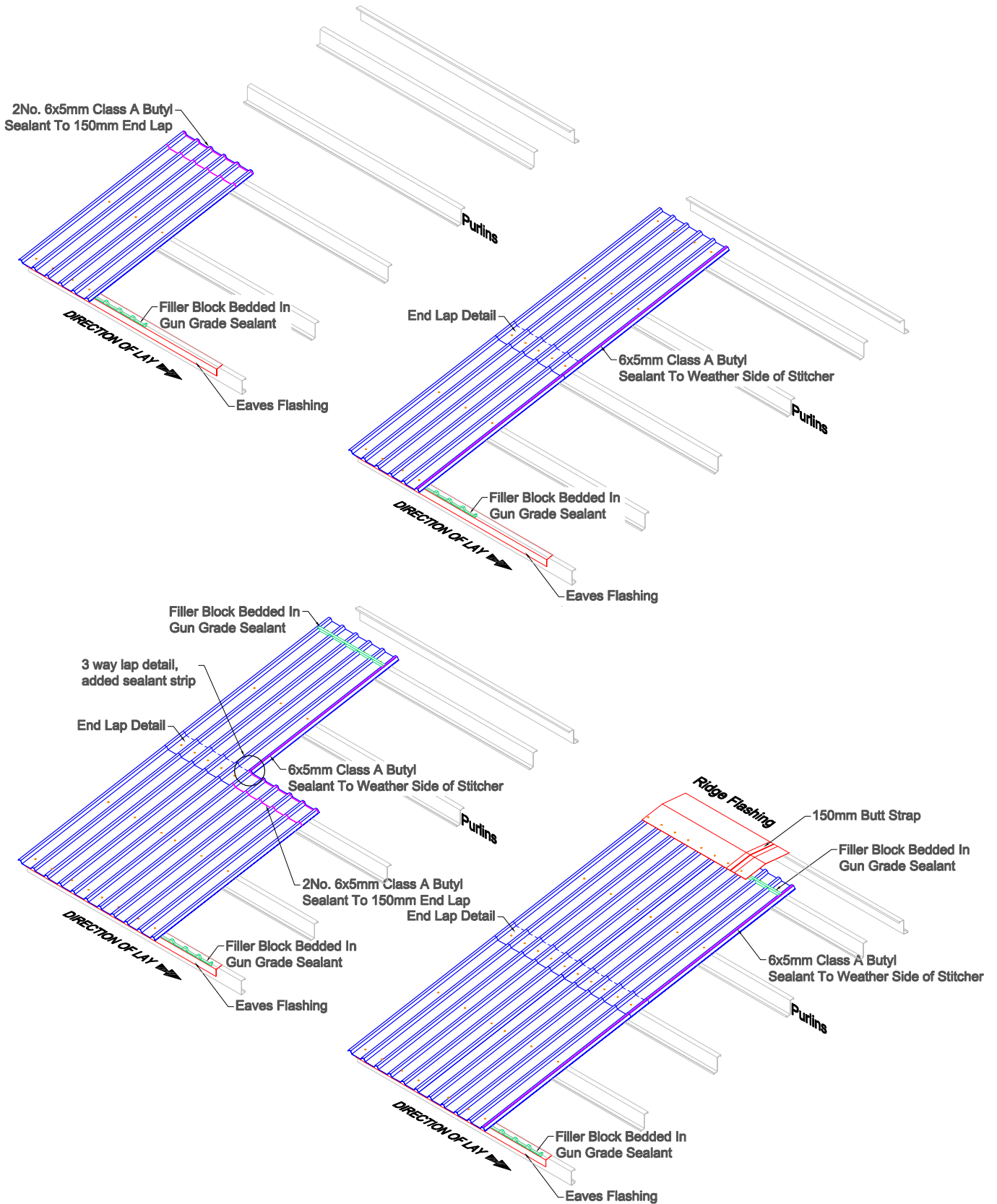

CONSTRUCTION DETAILS

Mono Ridge

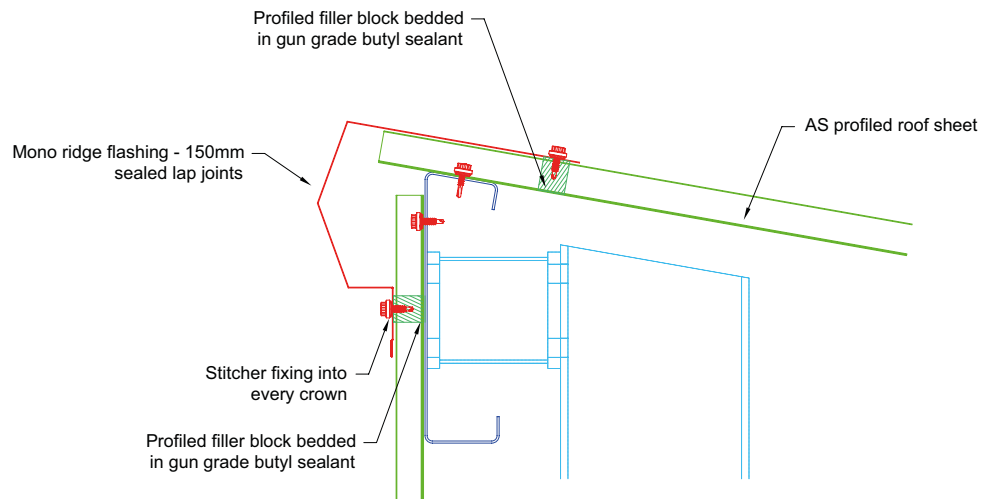

Ridge

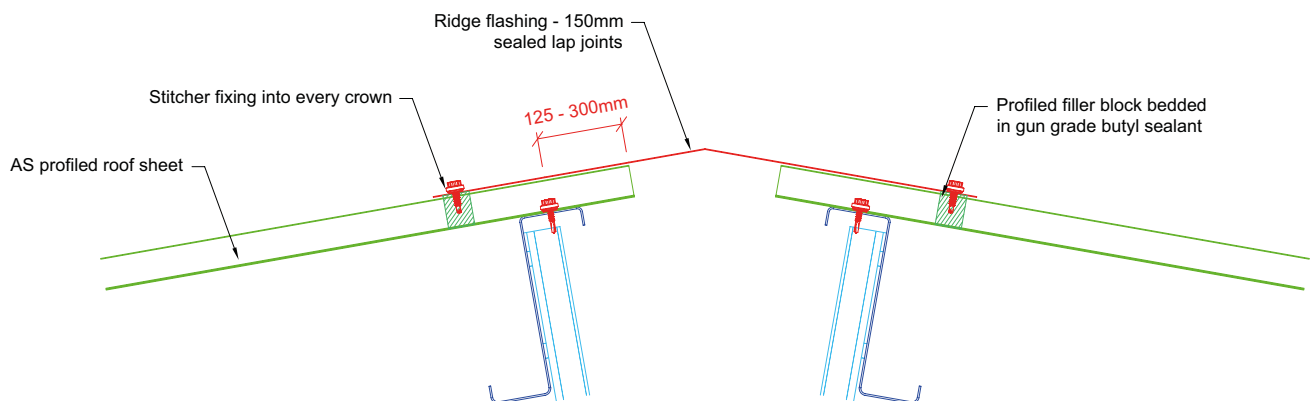

CONSTRUCTION DETAILS

Verge

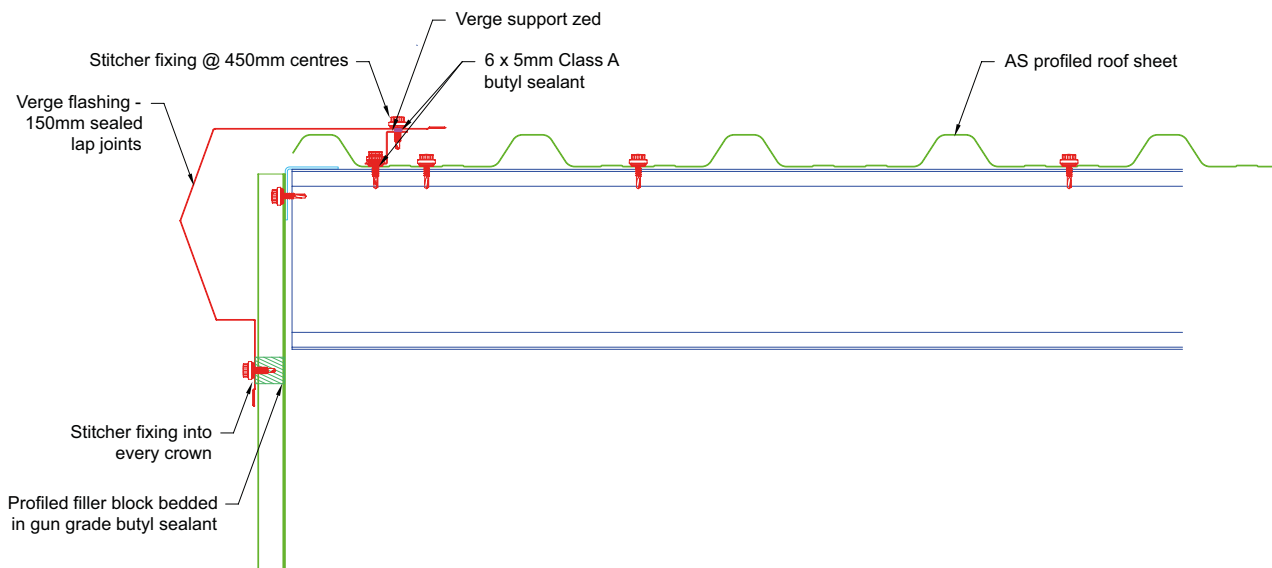

Eaves

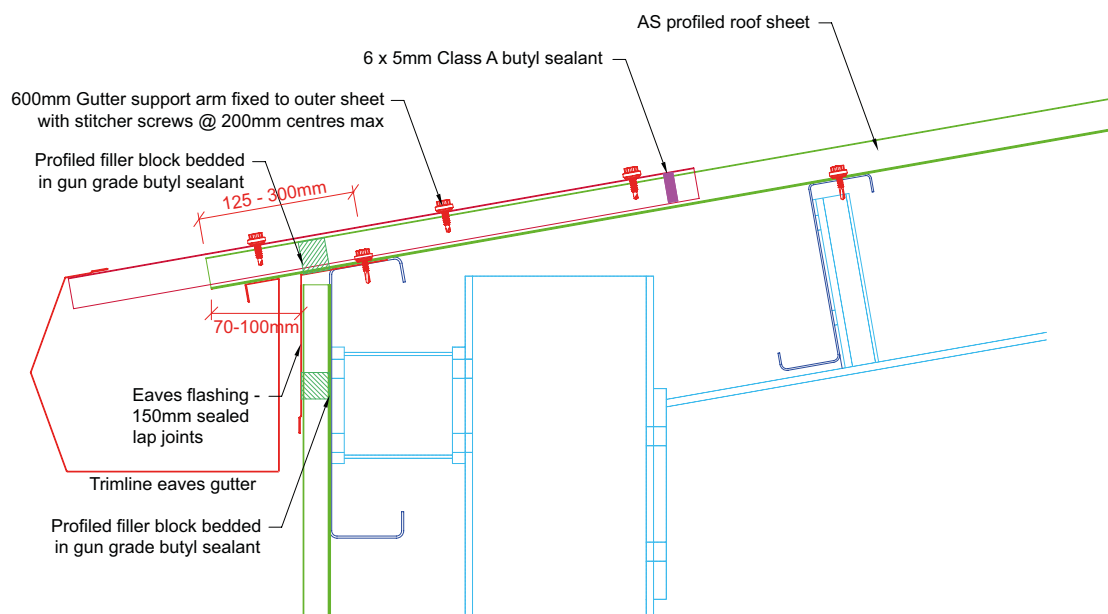

CONSTRUCTION DETAILS

Valley Gutter

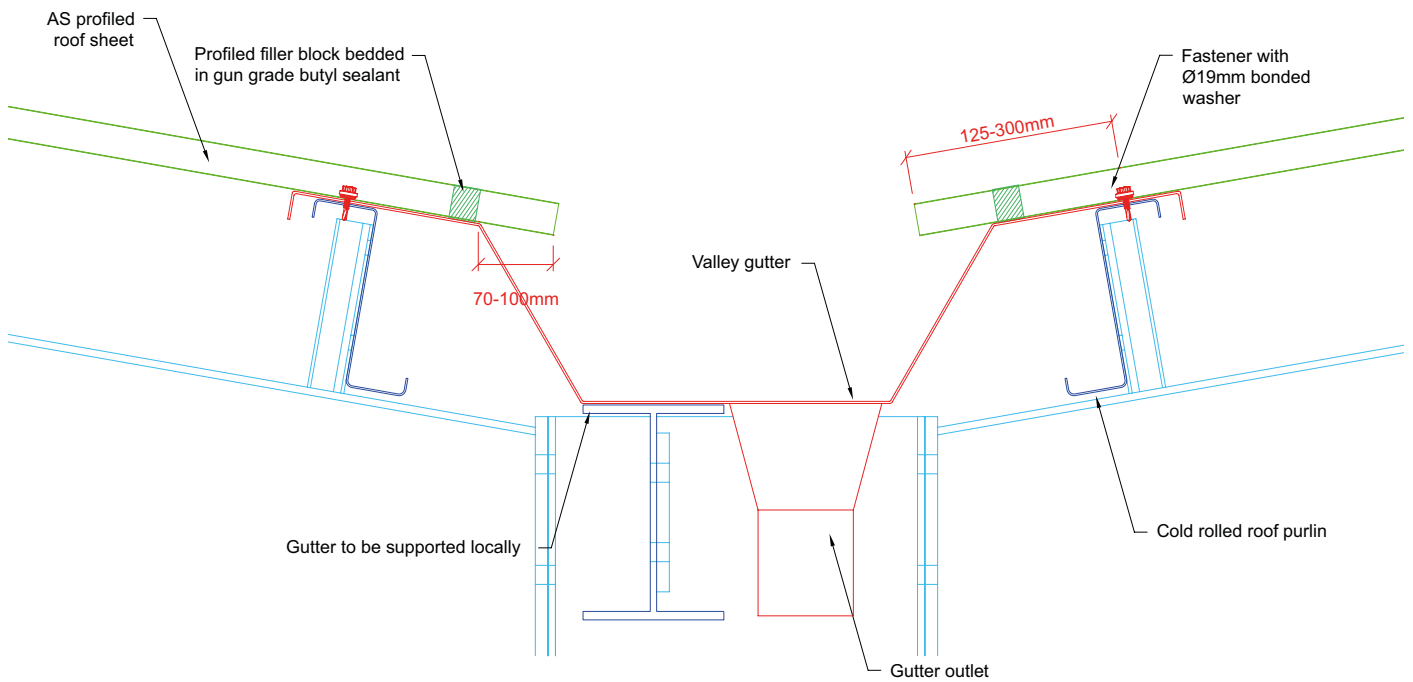

Drip Detail

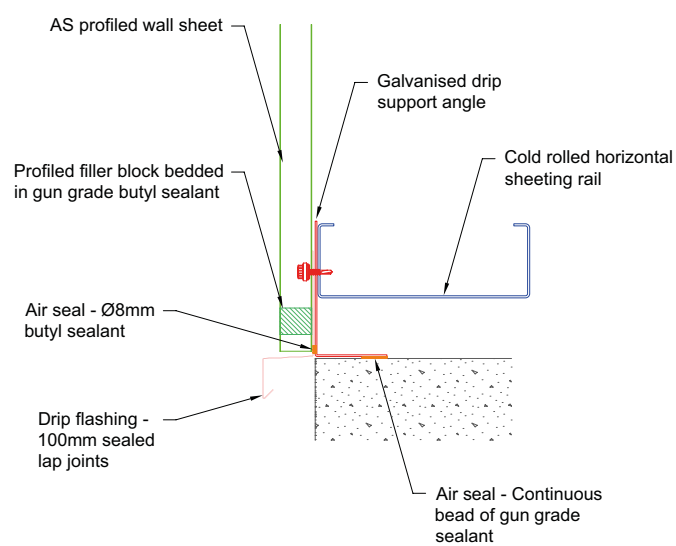

CONSTRUCTION DETAILS

Wall End-lap Vertical

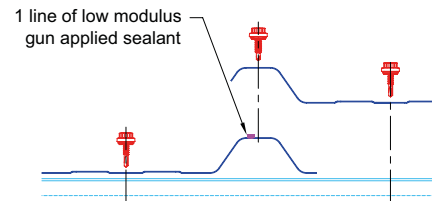
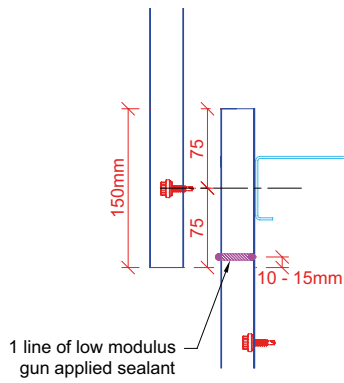

Wall End-lap Horizontal

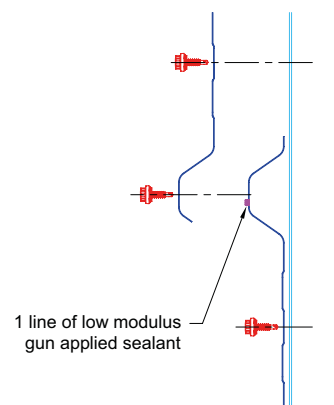
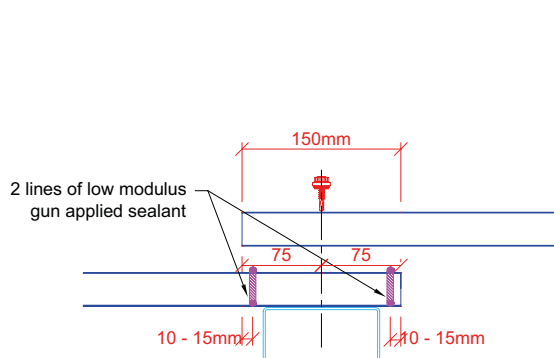

CONSTRUCTION DETAILS

Rooflight Installation

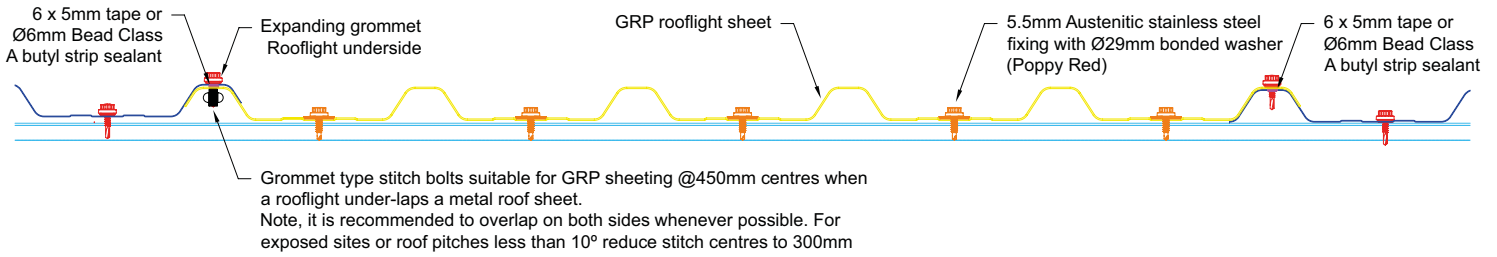

End-lap - Rooflight over Rooflight

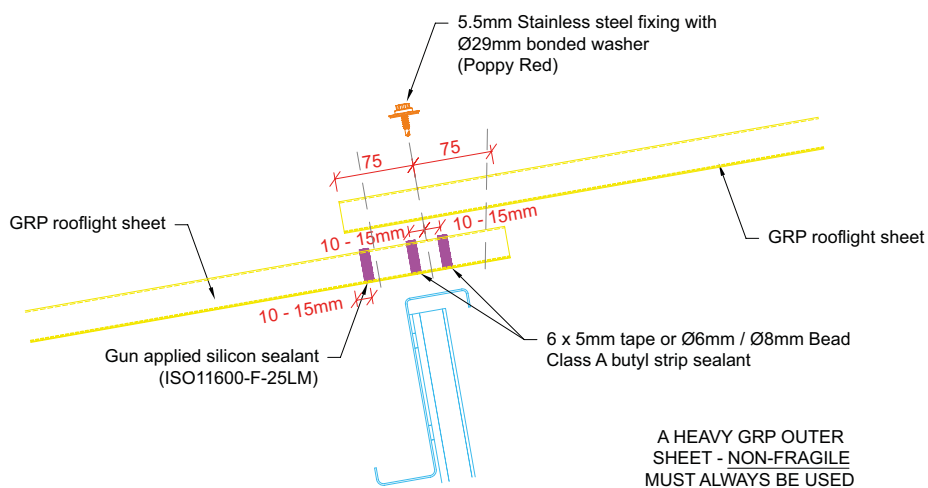

CONSTRUCTION DETAILS

End-lap - Cladding over Rooflight

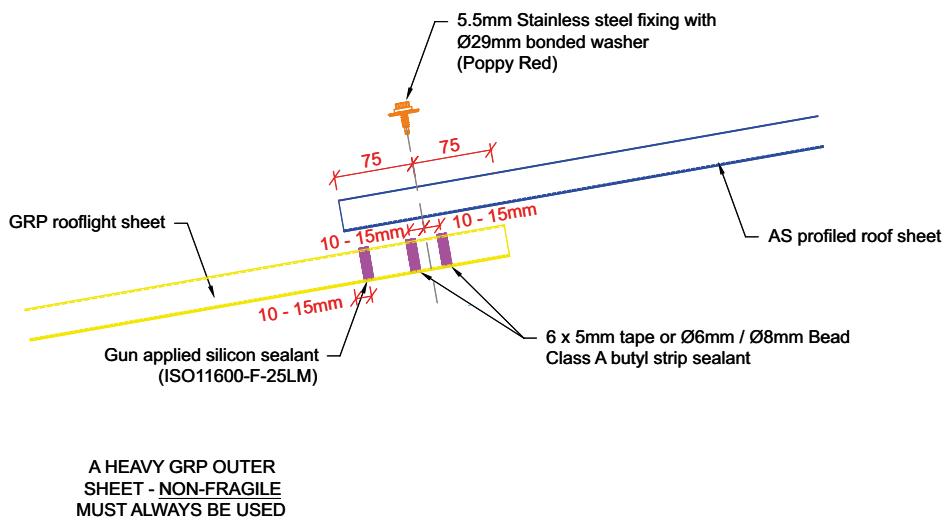

End-lap - Rooflight over Cladding

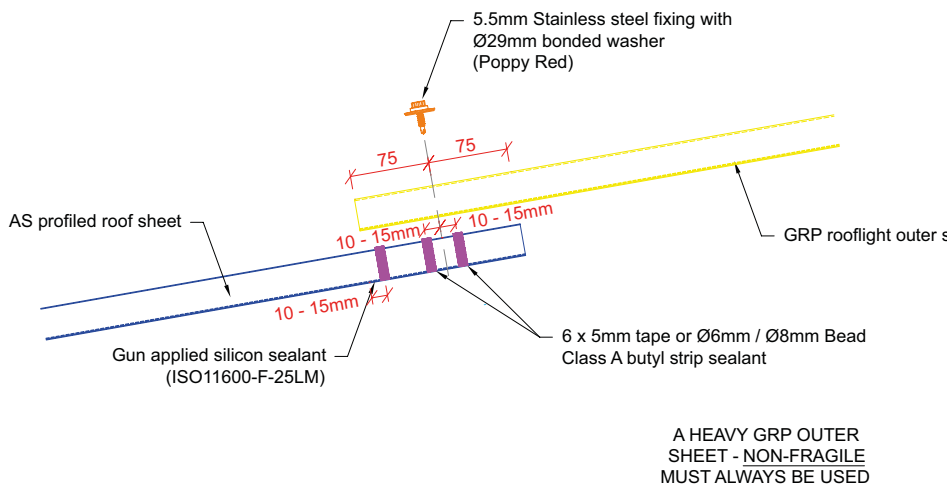

MAINTENANCE

Supply and delivery

All Steadmans Single Skin profiles are manufactured at Steadmans. Steadmans Single Skin profiles are supplied banded and in a protecting profiled packing sheet and are usually delivered direct to site. Off loading is the responsibility of the customer. Delivery by self off-load vehicles can be arranged.

Annual inspection

It is good practice to carry out annual inspection of the building exterior and to carry out any remedial work identified during the inspection, see table below.

Touch-up

Minor scuffing of the colour coating should not be treated. Deeper scratches which reach the substrate should be repaired with touch-up paint.

The touch-up paint should only be applied to the original scratch using a fine paint brush. As touch-up paint will dry to a slightly different colour than the original coating the area which is touched up should be kept as small as possible.

Checklist for annual inspection	
Item	Action ^{A)}
Establish a safe method of work	Check that the roof is non-fragile. ^{B)} Check that the safety equipment is tested in accordance BS EN 795 (including safety lines)
Leaks, inspect from inside for location	Repair as soon as possible and do not leave until annual maintenance.
Damage or decay	Repair or replace as necessary.
Accumulated debris, e.g. trapped leaves or pine needles	Clean away.
Gutters and drain pipes clean, and free draining	Clean out.
Gutter joints defective sealant or loose bolts	Repair.
Loose ridge or other flashings	Repair.
Missing foam fillers or evidence of damage by birds	Replace.
Staining caused by ponding or water	Seek advice from a roofing specialist.
Discoloured areas of the surface coating	Inspect the surface coating and attend to any peeling corrosion or other evident deterioration, as necessary.
Discoloured areas around fume extract ducts should be closely inspected	Re-coat without delay where attack of the coating has occurred.
Dirty rooflights	Clean to maintain light transmission.
Evidence of access to the roof e.g. for maintenance of ventilators	Touch-up any scratches in coating.
Missing/faded colour caps from fasteners	Replace.
Missing fasteners	Investigate and replace.
Corroded or degraded fastener (including sealing element)	Seek advice on replacement.
Loose fasteners, e.g. where the washer is not in contact the sheet	Tighten only fasteners that are loose. Investigate the cause.
Sealants visible on roof surface	Seek advice on replacement and suitability of the sealant.

^{A)} Where any defects are discovered, these should be reported to the client. Some of these items might be covered by a product/system guarantee, which should be pursued via the contractual chain.

^{B)} See ACR[M]001 "Red Book" [N1], ACR[CP]001:2014 "Orange Book" [1] for further guidance on non-fragile roofs (Recommended practice for work on profile sheeted roof) and ACR[CP]002 (Guidance Note for Safe Working on Fragile Roofs, otherwise known as the "Green Book" [30]).

TECHNICAL SUPPORT

Steadmans offers comprehensive technical support to designers and contractors working with Steadmans profiles, including:

- Technical brochures and data sheets for all Steadmans products
- CAD details
- Copies of test certificates
- Fixing calculations
- Design and installation guidance

Our web site offers full product and application information and downloads of construction details in AutoCAD and PDF formats.

www.steadmans.co.uk

To contact our Technical Department:

Telephone: 01697 478 277

Fax: 01697 478 530

Email: technical@steadmans.co.uk

Steadmans are always happy to provide advice on the specification of our single skin system and all of our other products for refurbishment and new build projects.



England & Wales

Warnell
Welton
Carlisle
Cumbria
CA5 7HH

Tel: 016974 78277
Fax: 016974 78530

Scotland & Ireland

Unit C
Coalburn Road
Bothwell
Glasgow
G71 8DA

Tel: 01698 819 050
Fax: 01698 801 764

Mill of Crichtie
Fyvie
Turriff
Aberdeenshire
AB53 8QL

Tel: 01651 891 668
Fax: 01651 891 698



E-mail: info@steadmans.co.uk
Online: www.steadmans.co.uk

