



Roofing with BURLINGTON slates - DESIGN GUIDANCE -



Contents

Introduction	02
Product information	03
Design principles	04
Design guidance	08
Accessories	13
Sitework	14
Technical support	17
Headlap tables	18

... a hundred times older than mankind, formed over aeons of time, fused by the heat of the earth's core, compressed by the weight of the earth's crust.

This brochure is all about the selection, detailing, specification and fixing of Burlington natural slates for the pitched roofing and vertical slating of new and refurbished buildings.

The information is intended for use by designers, by students and by roofers who wish to use this beautiful natural material to create durable weathertight roofs which are both practical and delightful to look at.

We also offer comprehensive technical support by telephone, fax and e-mail.

This design guide is supported by specialised information in the form of working details in AutoCAD, data sheets, standard specification clauses, and calculations available on CD-ROM and on our web site

www.burlingtonslate.co.uk.



This icon indicates that additional information is available on a separate data sheet and/or that detail drawings are available in AutoCAD format.

The Company

Burlington Slate Limited was founded in 1843 and is still owned by the Cavendish family. Our head office is at Kirkby-in-Furness in the English Lake District where our quarries are situated and we also have offices in London and Texas.

We manufacture roofing slate, slate cladding, paving, flooring, cills, copings and cappings and we also supply slate for landscape work.

We will be happy to provide you with brochures and further information on those products.

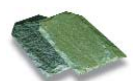



Burlington quarry two different types of slate, formed in different geological periods:-

Blue Grey slate is a metamorphosed sedimentary rock formed 330 million years ago in the Silurian period.

Westmorland Green slate was formed from metamorphosed volcanic ash some 500 million years ago and contains chlorides which impart a unique green colouring.

Burlington roofing slates are made by splitting the rock along its natural cleavage planes to produce thin plates which are then trimmed to shape and size. (Note: we make both imperial and metric sizes). The slate thickness varies; broadly speaking, larger slates tend to be thicker than small ones and Westmorland Green slates tend to be thicker than Blue Grey ones of similar size. The average thickness of a consignment of 610mm (24") long Blue Grey slates is 9mm whereas those up to 560mm (22") long will average 7mm thick.

610mm (24") long Westmorland Green slates average 12mm thick whilst those up to 560mm (22") long are of 10mm average thickness.

Both Blue Grey and Westmorland Green slates are of 2880 Kg/m³ density, non-combustible and unaffected by freeze/thaw cycling, atmospheric pollution, acid rain or salt spray. They will not rot or delaminate, do not encourage the growth of lichens or mosses and are compatible with all common building materials. The thermal conductivity of slate is approximately 2.0 W/mK.

Burlington roofing slates

We produce Burlington roofing slates in three different formats from both our Blue Grey and our Westmorland Green material; the three formats are:-

patterns

sized slates

randoms

Patterns are cut to fixed dimensions of length and width, the width being never less than half the length.

Sized slates are of a stated length but of various widths: the width is never less than half the length and it can be up to 435mm (17"). Thus a parcel of 510mm sized slates may range from 510 x 255mm (20" x 10") to 510 x 435mm (20" x 17").

Sized slates are ideal for use on lower pitches where larger pieces are needed to ensure a weathertight roof, especially if it incorporates hips and valleys.

Randoms are supplied in random lengths and widths, the width being never less than half the length.

Randoms are ordered by reference to the maximum and minimum required lengths - for example 460mm to 225mm (18" to 10"): they must be sorted on site by length and are laid to courses which diminish from eaves to ridge.

This traditional form of slating is very common in Scotland and the north of England; it requires the skill of an experienced slater and produces a most attractive roof with smaller slates at the top and larger slates at the bottom.

In addition to our range of roofing slates we also produce matching accessories in both Blue Grey and Westmorland Green slate (see page 13 for details).

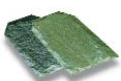
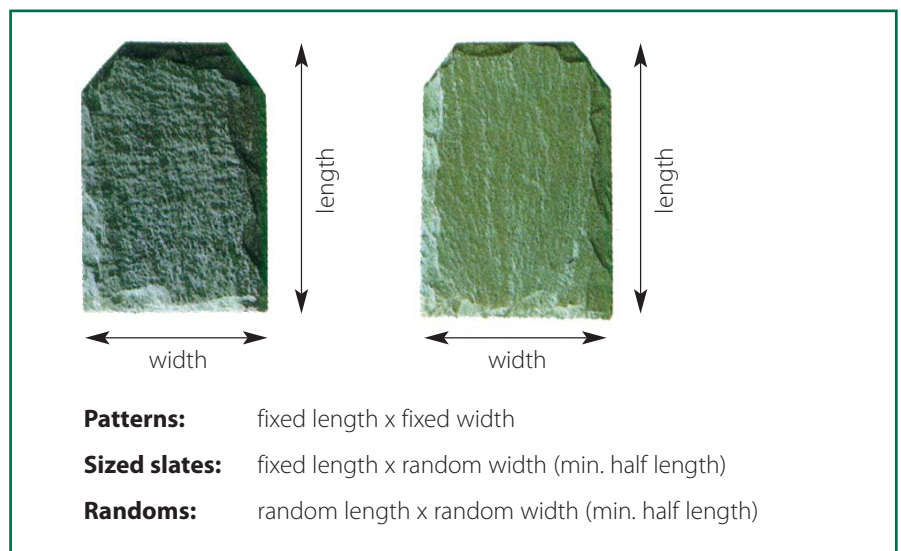

Design principles

Terminology

There are several terms commonly used in the slating industry to describe aspects of roofing slates and their application; these are the more important ones:-

Pitch: the slope of the roof framing relative to the horizontal.

Face: the upper side of the slate as laid and

Bed: the underside.

Head: the upper edge of the slate as laid and

Tail: the lower edge.

Margin: the exposed area of the slate as laid.

Lap: the distance by which the tails of slates in one course overlap the heads of slates in the course next but one below.

Bond (or Side Lap): the horizontal distance between the side of a slate and the side of the one immediately above it (the bond should never be less than the lap).

Gauge: the distance centre to centre of slating battens (and thus the depth of the margin). Gauge for sized and patterned slates is calculated by the formula:-

$$\text{Gauge} = \frac{\text{length of slate} - \text{lap}}{2}$$

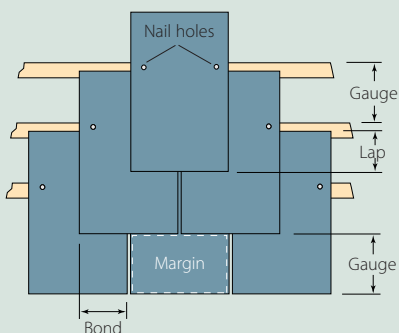

The fundamental design objective is to produce a well-detailed attractive slate roof which will protect the building from the elements - wind, rain and snow: that must be achieved in the context of the many factors which affect design:

- ❑ appearance
- ❑ mechanical resistance
- ❑ fire resistance
- ❑ mass/weight
- ❑ durability
- ❑ cost
- ❑ thermal resistance
- ❑ airtightness
- ❑ vapour permeability

The inter-relation of those factors is well illustrated if we consider roof pitch.

Pitch

The choice of pitch determines the space contained by the roof structure as well as the amount of roof exposed to view: as pitch increases smaller slates with shorter lap may be used: slate size in turn affects dead load which affects the size of the rafters.

From many points of view the steeper the pitch the better for weathertightness, durability, appearance and practicability. A steeper pitch will drain more quickly, allowing slates to dry off: steeper pitch allows greater span for a given rafter size and opens up the possibility of a useable loft space.

Building Regulations determine the **maximum pitch** of a roof is 70°; above that is deemed to be a wall. Burlington roofing slates can be used as wall cladding at pitches from 70° to vertical.

The **minimum pitch** we recommend for Burlington slates will depend on location, exposure, size of slates and lap. Many Burlington slate roofs in the north of England are still performing well after many years at pitches as low as 15°.

Because of the risk of wind driving rain and snow through any watershedding roof covering, it is usual practice to incorporate a waterproof underlay as a second line of protection.

We recommend the use of a modern lightweight breather membrane as described under 'Sitework' on pages 14 - 16.

Loading and structure

The roof structure must be sufficiently strong and stable to support all the loads upon it:-

- ❑ **dead load:** the weight of the materials used in the roof construction
- ❑ **imposed loads:** snow load and loads imposed during access for cleaning and maintenance
- ❑ **wind load:** the wind induces positive and negative air pressure differentials which affect both structure and covering, particularly at gables, eaves, ridges and penetrations such as chimney stacks and dormers. Wind load varies according to location and local surroundings and with the height and shape and orientation of the building. Wind load is calculated using the methods given in BS 6399-2: 1997.

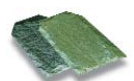



Weather resistance

Roofing slates are a discontinuous roof covering: rainwater falling on one slate is shed onto those below. Successive courses are staggered to prevent rain penetrating the open joints. The effectiveness of this watershedding action relies upon a combination of the roof pitch and the amount by which slates overlap, both on the slope (headlap) and across the courses (sidelap). Laps are determined by the size of the slates: larger slates allow greater laps and are therefore more suitable for shallower pitches.

Water passing through the joints between slates can be drawn by capillary action and wind pressure over the face of slates beneath, an effect known as creep. The nail holes in slates should be positioned outside the area which might be affected by creep.

The surface texture of Burlington slates reduces the possibility of capillary action and, provided the guidance given here on head and side laps and pitch is observed, creep will not present a problem.

When designing a slated roof for a given location the designer must consider exposure (figure 1), pitch, gauge and slate size. For most sites the figures given in the tables on pages 18 and 19 apply. However, where abnormal weather conditions may be expected (elevated sites, sites near the coast, localities which experience heavy falls of snow) take account of those local conditions. Seek guidance from an experienced roofing contractor familiar with the area and adopt his advice. He may, for example suggest increasing the size of slates and/or lap.

To avoid rainwater runoff wetting the supporting walls it is good practice to extend the roof at the eaves: the overhang may be as little as 100mm or as much as a metre depending upon the Architect's approach to the modelling and form of the overall roof: common practice is to overhang 300 - 400mm at eaves.

It is also normal practice to fit eaves gutters drained by downpipes. The size of the gutters and the size and spacing of downpipes should be determined from BS EN 12056-3:2000 'Gravity drainage systems inside buildings: Roof drainage, layout and calculation'. Alternatively, the roof may be designed with wide eaves to throw the runoff clear of the walls. Dormers with good eaves overhang do not require an eaves gutter.

Thermal performance

Building Regulations require reasonable provision be made to conserve energy; table 1 shows suggested U-values for roofs. Current regulations address only heat flow by conduction through the materials of construction; it is now widely recognised that heat loss by convection is at least as important and that substantial improvement in energy efficiency can be achieved by minimising gratuitous air leakage.

Thermal insulation may be applied at ceiling level, leaving the loft space and roof structure uninsulated - a cold roof - or at rafter line, which ensures the whole loft space is insulated, creating a warm roof.

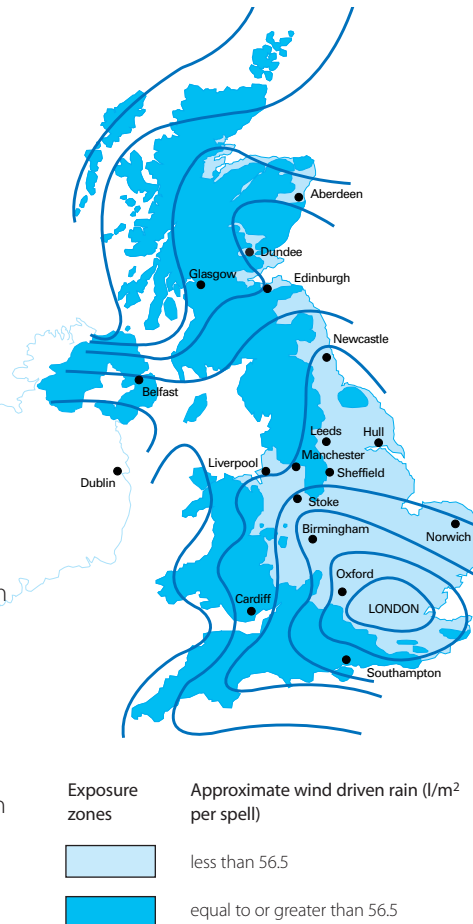

Figure 1: Categories of exposure to driving rain (from BS 5534:2003)

Table 1: Required U-values of pitched roofs (W/m²K)

		Dwellings	Other buildings
Elemental method	insulation at ceiling line	0.16	0.16
	insulation at rafter line	0.20*	0.20
Other methods	limiting values	0.35	0.35**

*0.18 in Scotland if dwelling boiler efficiency is low, see Technical Handbook part 6

**0.45 in Scotland

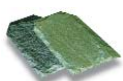

Cold roof construction

The heat and moisture within heated buildings create pressure which drives water vapour through the building envelope: the pressure is greatest at roof level.

Some underlay materials offer a high level of resistance to water vapour and create a risk of condensation which can damage the structure and the insulation. To reduce that risk it has been common practice to vent the loft space. The introduction of vapour open underlays makes it possible to construct more energy efficient cold pitched roofs without the need to vent the loft space but venting of the batten space is recommended: Burlington slate vents are described on page 13.

Warm roof construction

Warm roofs require different detailing from that used in cold roofs; they offer considerable benefits, including:-

- increased usable volume without any increase in the overall size of the building;
- reduced risk of condensation;
- more stable temperatures with a consequent reduction in thermally induced movement.

A warm roof can be formed by placing thermal insulation:-

- above the rafters or
- between the rafters or
- partly above and partly between the rafters.

Method A (figure 3) avoids thermal bridging through the rafters.

The insulant must be strong enough to support the imposed loads without being crushed.

The length and stability of fixing to secure the counterbattens are critical and will become more so as levels of insulation increase. This method cannot be used for loft conversions in existing buildings unless the roof is to be stripped and recovered.

Method B (figure 4) - which takes full advantage of the rafter depth to incorporate the insulation - includes repeat thermal bridging at all rafters which must be taken into account when calculating overall U-value. It is only suitable for use in conjunction with a vapour open underlay which does not 'tent' when in contact with the insulant.

Method C (figure 5) is often adopted when converting an existing roof to form habitable space in loft conversions by fitting insulation from within.

If the existing underlay is of bituminous felt, the internal lining must incorporate an effective vapour control layer and a vented gap must be left between the underlay and the top of the insulation.

Method D (figure 6) offers the advantages of method A but requires shorter fixings to secure the counterbattens. Some rigid insulation boards for use in this method offer good resistance to the passage of vapour but, when assessing overall performance, the designer must take account of the reduced resistance at joints between boards.

Air leakage at joints can be prevented by using as the underlay a suitable breather membrane, fully supported by the insulation: such an underlay can achieve a fully sealed roof with no risk of interstitial condensation.

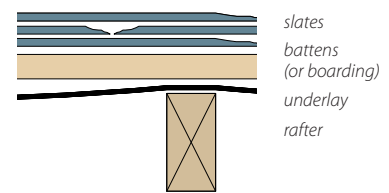

Figure 2: section through typical cold roof construction with slates

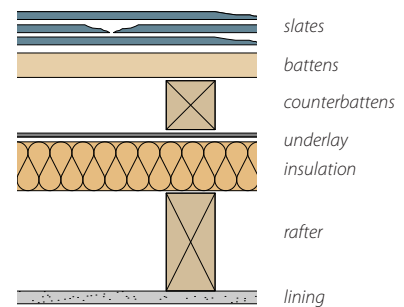

Figure 3: insulation above rafters

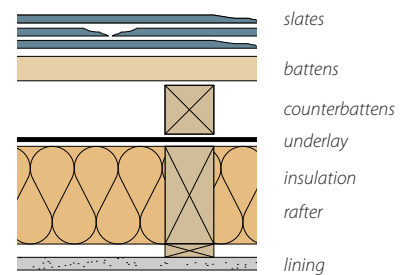

Figure 4: insulation between rafters (full fill)

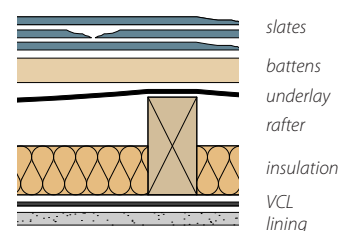

Figure 5: insulation between rafters (partial fill)

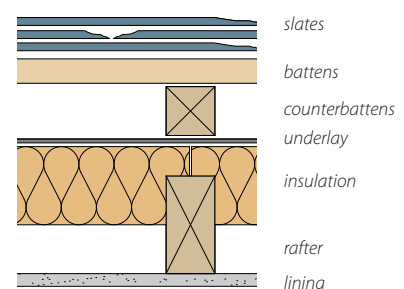



Figure 6: insulation above and between rafters







Controlling condensation

In cold roof constructions which include a bituminous felt underlay with high water vapour resistance, water vapour passing through the ceiling will condense on the underside of the felt, leading to a high risk of damage.





 Building Regulations require roofs be designed to avoid damage by interstitial condensation to structure and to thermal insulation. To counter that risk, the 'deemed-to-satisfy' solution given in Approved Documents and Technical Standards to Building Regulations, is to promote air movement by providing gaps at eaves and, where necessary, ridge.

Alternative solutions

An alternative method of avoiding condensation is to control the generation and movement of water vapour within the building as recommended in BS 5250. The design should:-

-  minimise internal vapour pressure by removing moist air at source from areas such as bathrooms, kitchens and laundries by means of mechanical extract or passive stack ventilation systems;
-  minimise the transfer of moist air to the loft space by fitting a sealed loft access sited in a dry area such as the landing, and seal around all services which penetrate the ceiling;
-  ensure the construction is progressively more vapour open from inside to outside.

Another solution, which is more energy efficient, is to form a sealed roof, constructed to avoid air infiltration by:-

-  incorporating an underlay which is both airtight and very open to water vapour;
-  sealing the interior against air infiltration;
-  using counterbattens on top of the underlay to increase the depth of space beneath the slates and
-  encouraging air movement outside the underlay.

Air movement in the batten space will depend upon orientation, pitch, the depth of battens and the air permeability of the outer covering. We can supply in-line vents to match all Burlington roof slates.

In a warm roof the risk of damaging condensation is reduced because the loft space is maintained above dew point temperature. Warm roofs formed by converting existing roofs with underlays of bituminous felt require a vented airspace at least 50mm deep between the new insulation and the old underlay.

Fire

Burlington slate achieves the highest designation for internal and external spread of fire, making it suitable for use without restriction.

The roof covering must be detailed to prevent the spread of flame across a party wall. All combustible materials must be cut back neatly to each side of the party wall and the space between the top of the wall and the slates filled with non-combustible packing. The slates should not lift where they cross the party wall.

Refurbishment and repair

A Burlington slated roof requires very little maintenance but occasionally an individual slate may be damaged or broken and need to be replaced. Unless the damage is at or near the top of the roof it is difficult to repair economically. The answer has been to fit a replacement slate using a folded copper or lead hook 'tingle' to support it at the tail. An alternative solution is to use a proprietary component attached to the bed of a new slate which can be slid into place (see page 13 for details).

From time to time roof coverings need to be renewed for various reasons, including nail failure and batten decay. Burlington slates, thanks to their extreme durability, can be salvaged and recycled. They should be stripped carefully from the roof, any broken ones replaced with slates of matching material and size and the roof reslated. Burlington produce all their roofing slates in both metric and imperial measure so matching existing slate dimensions is easily done.

Burlington slates may also be used to replace other roof coverings which have failed. Designers should consider:-

-  the need for planning consent when re-covering the roof of a listed building or a building in a conservation area;
-  whether the roof structure is adequate to support the new slates;
-  any detail modifications necessary to accommodate the new slates.

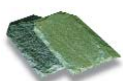

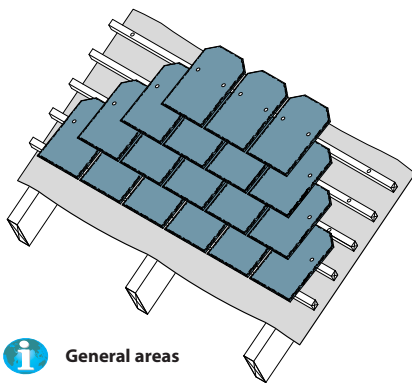

General areas

Slating general areas

More than 80% of the area of an average roof consists of straight forward slating: the slates are normally half lap bonded and centre nailed, (although head nailing is used in some areas for fixing small slates), with two nails through each slate close to the horizontal centreline and 20 - 25mm from each edge. Holes for the fixing nails are punched out from the bed of the slate using a holing machine; Burlington can supply slates pre-holed if required. The punch causes a spalling on the face of the slate into which fits the head of the slating nail. Figure 7 illustrates this fixing technique which results in three slate thicknesses above each batten.

As with brickwork, slating must be carefully set out, taking account of rafter length, the number of courses and the overall width of the roof area.



The joints between adjacent slates should be kept open 3 - 4mm to encourage free drainage. When laying patterns the 'perpend' joints between the slates in alternate courses should line through up the roof slope.

Nails should not be driven hard down onto the slate, but they must hold the slate firmly to avoid rattling. The nail head should nestle in the spalled hole so as not to project; projecting nail heads prevent successive courses lying snugly onto the slates beneath and are likely to lead to wind chatter and increased risk of rain and snow penetrating the slating.

The shear force exerted on the slating nails is greater with steeper pitches. Vertical and steeply sloped surfaces should be covered with smaller slates and vertical slating should always be centre-nailed.

General areas of slating are bounded by verges, eaves, ridges, valleys and hips and are interrupted by penetrations such as dormers, chimney stacks, roof windows and vents.

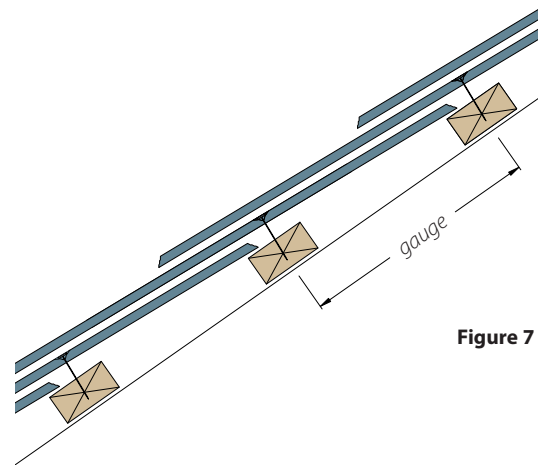
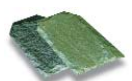

Figure 7





Verges

The verge - or edge - of an area of slate roofing must be formed with full slates and slate-and-a-half slates in alternate courses to maintain the bond. Verges occur at gables.

Traditionally a gabled verge is finished in one of three ways:-

- the wall is extended above the roof plane and capped with coping stones (water tables); the slating then abuts the extended wall;

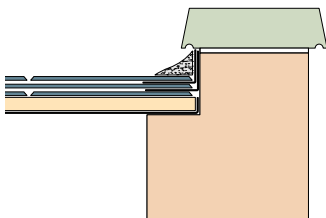

- the slating is extended to oversail the wall by 40 - 50mm;

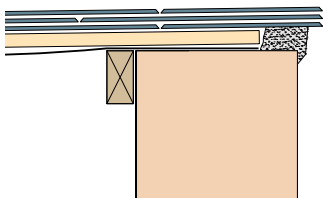

- the roof framing is extended beyond the gable and covered with sarking boards onto which the slates are laid.

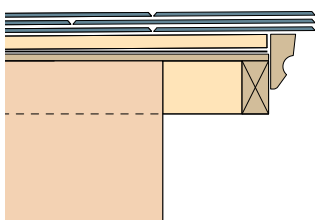

The water table detail is more common in very exposed locations where oversailing verges are susceptible to wind damage and exposing the edge of the slating is likely to allow water to penetrate.

BS 5534 suggests oversailing verges may be formed with an undercloak onto which the slates are bedded and pointed in mortar. However, Burlington recommend it is better to form an oversail of 40 - 50mm without an undercloak, keeping the batten ends back 50mm from the wall face: each slate must be twice nailed and the gap between the wall head and the bed of the slates should be filled with mortar struck off at the wall face.

When a verge is formed over timber barge boards a timber cover mould can be fitted, scribed to the bed of the oversailing slates. Another variation is to apply a hardwood batten on top of the verge slates, secured with brass screws to the timber framed barge boards.

A slight uplift of the battens at the verge will help to prevent water draining over the edge of the roof; it also adds to the overall appearance, helping to avoid an apparent falling off of the roof plane.

Eaves

Slate laying begins at the eaves with a first course of small slates laid "upside down" and head nailed to a supplementary batten fixed just below the first gauged batten. The tails of the eaves course slates must be lifted to create the correct plane for the following courses: they are supported on a tilt fillet, or on a double thickness of battens, or on the fascia board.

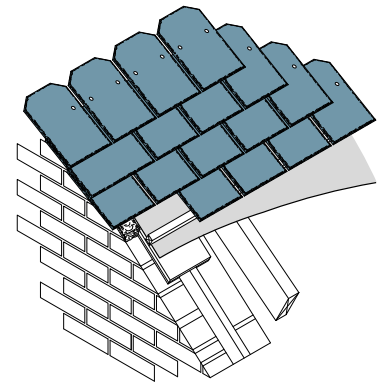

Verges 

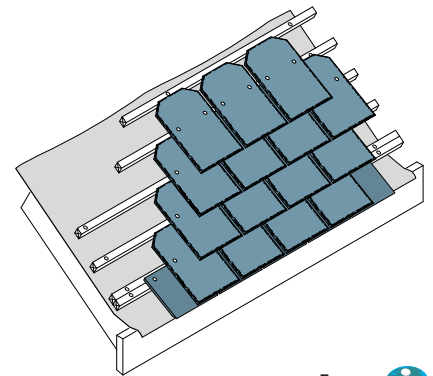

Eaves 

When an open eaves is used (that is, one with no soffit board) it is good practice to cover the overhanging rafters with softwood sarking boards which present an attractive appearance from below and form a base to which the eaves courses can be nailed.

The slating at eaves is sometimes laid on sprockets which reduce the pitch over the lowest few courses; the visual effect is to soften the roof profile at its junction with the supporting walls. If sprocketed eaves are used the reduced pitch should not be less than that recommended for a given location.

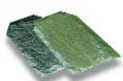

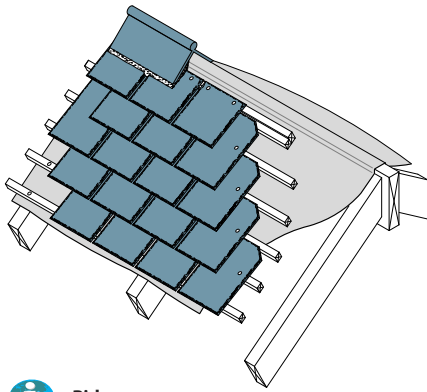

Ridges

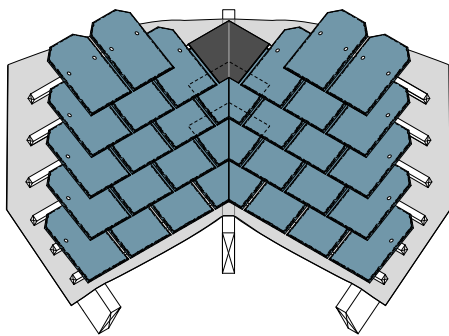

Mitred valleys

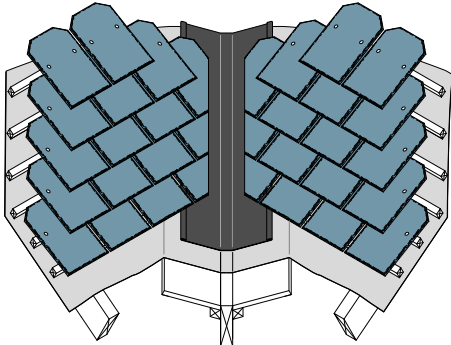

Open valleys

Ridges

A ridge is formed by the junction of two roof planes and must be capped with an impervious covering: a careful choice of ridge covering will enhance the character of the roof:-

- Burlington slate ridge tiles, including a slate roll, produce a ridge which is in keeping with the rest of the roof covering;
- clay ridge tiles, socketed or butt jointed, provide a contrasting finish;
- a wood roll, fixed to the ridge board and covered with lead, zinc or copper is a well tried traditional solution.

To maintain the weatherproof covering, slates in the penultimate course should have their top corners removed (shouldered) to allow the top course to be fixed. Top course slates must be cut to a length which maintains the margin and be head-nailed to a double batten to ensure the slates sit tightly on the course below. The heads of the top course slates may be set in mortar to increase resistance to wind uplift.

Ridge tiles, whether slate or clay, should be edge-bedded to the roof slope with mortar; the amount of exposed mortar at the lower edge being kept as small as possible. Provide slate slips set on the ridge board beneath the joints of butt jointed ridge tiles. The end ridge tiles should be lifted slightly to strengthen the visual line of the ridge and the exposed ends filled with mortar and slate slips.

Where the ridge of a dormer or of a lower roof runs into another roof slope, the junction must be weatherproofed with a lead saddle.

Valleys

Valleys are formed by the intersection of two roof planes at a re-entrant angle: they act as steep sloping gutters, receiving all the run-off from both roof planes, and must be detailed and constructed with care to ensure weathertightness. The pitch of a valley (and of a hip) will always be much lower than that of the intersecting roofs (see table 2 on page 11): for example, 35° roof pitch will produce a valley at 26° pitch.

Valleys should be planned to bisect the angle between adjacent roofs of the same pitch: slate courses will then line through, giving a neat appearance and the possibility of forming a swept/laced valley.

- **mitred valleys** are formed using angle cut slates interleaved with metal soakers and produce no visual interruption to the surface material. Here the mitre cut should be made from the bed of the slate to allow the tightest fit on the centre line of the valley rafter. As for mitred hips, large slates are needed to form mitred slate-and-a-half at valleys: Burlington blue grey slates are available in suitable sizes and have been successfully used for many years to form mitred valleys.

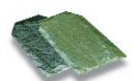



- ❑ **swept/laced valleys** provide a completely slated surface with courses running from one slope to the other in a continuous sweep; they provide an attractive weathertight solution.
- ❑ **open valleys** can be formed by creating a raking verge to each roof slope, set back some distance from the centre line of the valley rafters. A lining of zinc, copper or lead is used to weatherproof the valley gutter with a clear width of 150mm. To support the valley gutter lining it is essential to provide layer boards; set flush with the top face of the roof framing, to which the gutter lining is fixed.

Where the slating laps an open metal-lined valley do not joint or bed the slates in mortar.

Table 2

Main rafter pitch	Valley rafter pitch
35	26.3
40	30.7
45	35.3
50	40.1
55	45.3
60	50.8

Hips

When two roof planes come together to form an external angle the joint is known as a hip. Hips, like valleys, should be planned to bisect the angle at which the two roofs join and both roofs should be at the same pitch; the slate courses will then line through.

There are several ways to provide a weatherproof cover to a slated hip:-

- ❑ **mitred hips** can be formed, using angle cut slates interleaved with metal soakers so that no material other than slate is visible. The mitre cut should be made from the face of the slate to give a clean straight edge allowing slates to fit closely together down the centre of the hip. A soaker of zinc or lead must be inserted between successive courses to make the joint waterproof; soakers are nailed to the battens and dressed down each roof slope with their bottom edge just covered by the slates above. Burlington blue grey slates are available in very large sizes suitable for forming mitred hips. Because very large slates are needed to cut mitred slate-and-a-half slates at alternate courses, this form of hip is not normally suitable for slopes below 30°.

- ❑ **lead covered hips** can be formed by securing a wood roll to the hip rafter, covering it with sheet lead dressed over both roof slopes with the wings secured by lead clips. Zinc and copper sheet can be used in a similar fashion.

- ❑ **tiled hips** can be formed using Burlington slate ridge tiles or clay ridge tiles, bedded as described for ridges. To provide support for the bottom of a tiled hip it is good practice to fit a hip iron secured to the foot of the hip rafter.

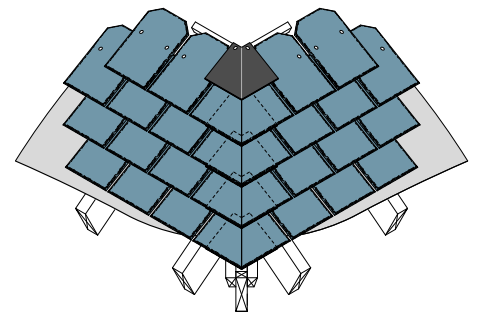

Mitred hips 

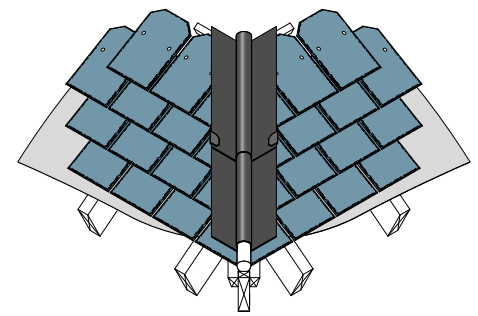

Lead roll hips 

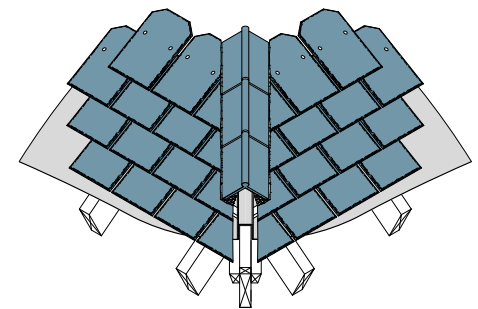

Tiled hips 

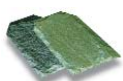

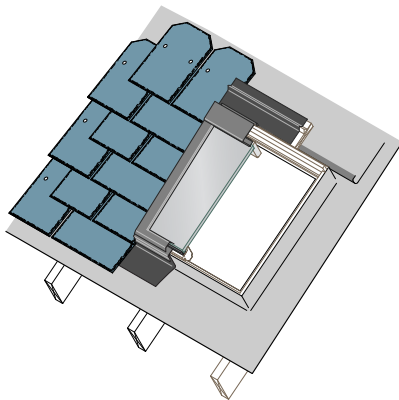

i Roof window

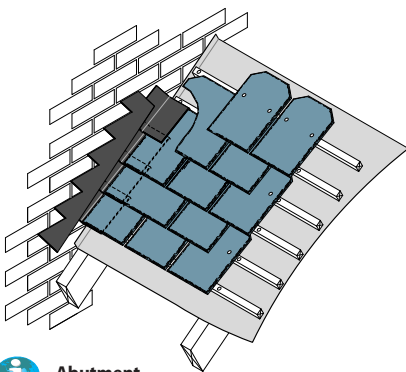

i Abutment

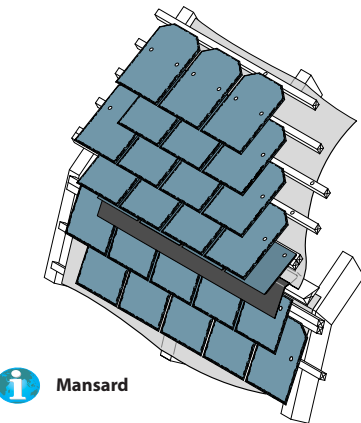

i Mansard

Penetrations

Wherever the general area of slating is interrupted or penetrated - for example by a dormer, a roof window, or a chimney stack - or where the plane of the roof changes - as in a mansard roof - detailed weatherings and flashings are required to assure the junctions are weathertight. Traditionally, those details involve the use of sheet metal; lead, zinc or copper.

At the back of a chimney stack, or at an internal valley gutter, the slating must be treated as already described for the eaves of a roof. A metal gutter must be provided, complete with suitable drainage falls and discharge points, turned up and covered by an apron flashing.

Abutment details

Where the side of an area of slating abuts a vertical surface such as a wall, the bond must be maintained by using slate-and-a-half slates in alternate courses. A metal soaker, bent through 90°, is interleaved at every course with the top turned over the head of the slate. Each soaker should extend 100mm onto the slate and 75mm vertically; a cloak flashing is then attached to the vertical surface, covering the soakers and stopping 10 - 12mm from the face of the slates.

Where the top of an area of slating terminates against a vertical surface - as for example a lean-to roof - the topmost courses must be treated as already described for a ridge.

Changes of roof pitch

A roof may consist of two planes at different pitches - for example when a shallow slope merges with a steeper one or in a mansard roof.

Slating is often applied to mansard roofs. The two slopes at different pitches should be regarded as separate and self-contained roofs with the slating at the foot of the upper plane treated as an eaves and the head of the lower plane treated as a ridge. The joint between the two planes is covered with a sheet metal flashing - normally lead - dressed over the lower roof and under the upper roof.

In a mansard roof a rounded wood roll - a torus - is used in good quality work to define and regularise the line of the lead work and facilitate its fixing.

Vertical slating

A practical and attractive way of providing weather protection to a vertical wall is to cover it with slates: this is particularly suitable for the cheeks of dormers and similar features in a slated roof.

The wall should be covered with an underlay, (lapped over that to the roof), counterbattens and battens: the use of counterbattens reduces the number of fixings to the wall and ensures a clear drainage path for any wind-driven rain which penetrates the slating.

Vertical slating is usually centre nailed using small size slates, the top course being made with short slates to maintain a margin and cloaked with a metal flashing.

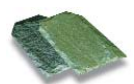



Burlington offer a range of accessories for use in conjunction with Burlington roofing slates to complete a durable and weathertight roof covering.

Vents

Purpose made fittings of matching slate, designed to:-

- vent the loft space in a cold roof;
- vent the batten space in a warm roof;
- terminate soil vent pipes;
- terminate building ventilation systems.

 You can find full details of those accessories in our separate brochure "Natural slate vents by Burlington".

Slate clips

In order to replace a damaged slate in an existing roof it is necessary first to remove the damaged slate and the nail securing it, this can be done with a slater's hook or ripper.

A proprietary clip, made of polypropylene, is pop rivetted to the bed of a matching replacement slate which can then be slid into the gap and pushed up until the clip snaps over the slating batten.

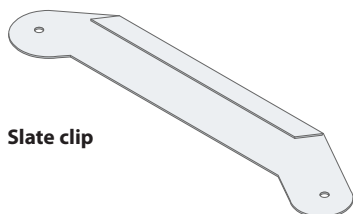

Slate clip

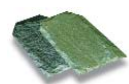

Ridge vent

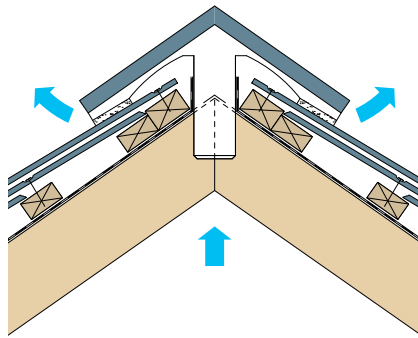

Ridge vents are available to suit pitches from 22.5° - 60°.

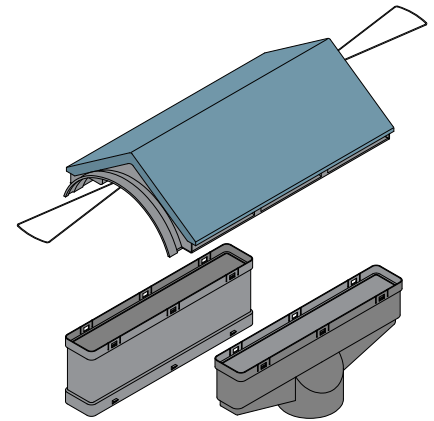

Ridge vent

Slate vents

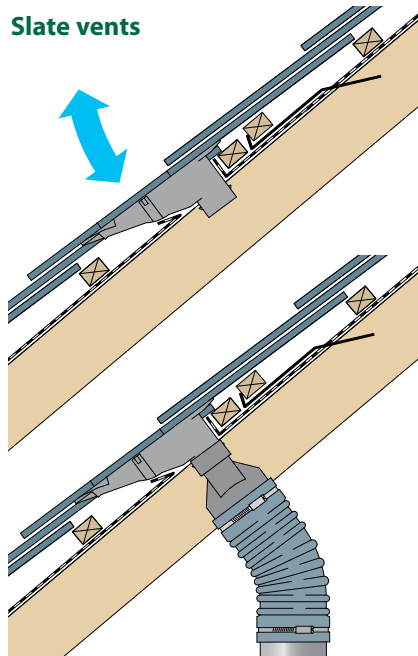

Natural slate vents available in slate sizes 510 x 305 and 610 x 305mm.

Soaker vents to suit slates 230 - 450mm long and 450 - 610mm long.

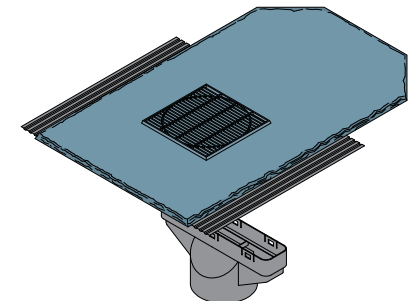

Natural slate vent

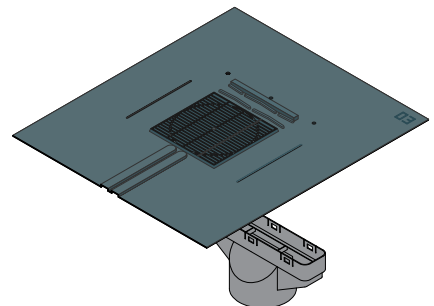

Soaker vent

Slate clip

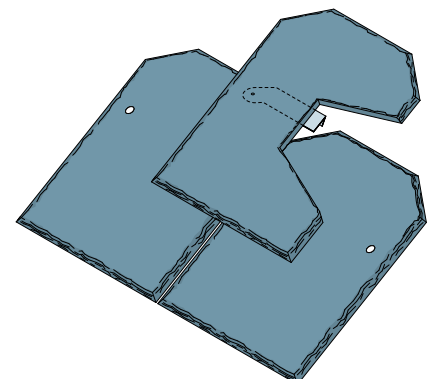
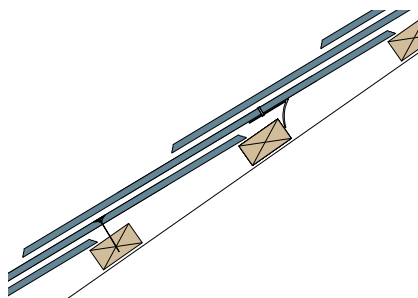

Mortar

For bedding and pointing slates and ridges we recommend the use of mortar made from one part hydrated lime to one part Portland cement to six parts sand: if it is proposed to use a plasticizer or other additives you should consult the manufacturer of those materials.

In order to maintain the fine overall appearance of the finished roof do avoid spreading mortar over the face of slates - keep it well cut back at ridges - and do protect uncured mortar from frost.

Battens, counterbattens and sarking

We recommend the use of sawn softwood for the support timber in a slated roof. Battens 25mm thick x 50mm wide are adequate for all rafter spacings up to 600mm: they are substantial enough to avoid bounce when driving in the slating nails and to support all sizes at any pitch. The same size timber may be used as counterbattens.

25mm thick sawn softwood sarking boards are readily available in a range of sizes, 150mm widths are commonly used, either for the whole roof or in local areas such as overhanging eaves and gabled verges. The boards are normally laid with open gaps of 3 - 4mm between them and offer low resistance to the passage of water vapour.

Panels of plywood and OSB are also used as sarking, plywood being particularly useful on curved surfaces. These panel materials are more vapour resistant: check the risk of condensation when using them.

Preservative treatment of the timber is not necessary in a well designed roof where the equilibrium moisture content should not be greater than 20%. In specific areas of the country treatment against beetle infestation is a requirement under Building Regulations.

Flashing materials

To secure a weathertight slated roof, sheet metal flashings are required at junctions with other materials and at verges, abutments, hips and valleys.

The most commonly used material is sheet lead which is easily worked, and very durable. Copper, zinc and aluminium are also suitable.

Table 3 lists the minimum code of lead sheet we recommend for specific applications: to avoid failure due to thermally induced movement the size of individual pieces should be limited; refer to the relevant material standard for guidance.

Table 3

Application	Code no.
Flashings	4
Soakers: abutments, mitred hip & mitred valley	3
Aprons: chimney & roof lead	4
Gutters: chimney & linings	5
Ridge & hip rolls	4
Valley linings	5
Saddles	4
Clips	6

Fixings

Timber battens and boards should be fixed with galvanized or stainless steel nails, then should comply with the relevant part of BS 1202: wire nails with ringed or helically threaded shanks are recommended.

Slating nails should be copper or silicon bronze, with a diameter of 3.35mm and of sufficient length to penetrate a minimum of 15mm into battens. We do not recommend the use of galvanised nails for fixing slates: over time the galvanising is worn away by slight movements in the slates and corrosion will lead to nail failure.

Proprietary fixing devices are available from several manufacturers and are particularly recommended for use in warm roofs where insulation overlaps the rafters. See, for example Proctor PR nails and Helifix In Skew 600.

Underlays

An underlay must be watertight and airtight to perform its two main functions; protection against rain, snow and dust which may be blown through gaps between slates and protection against positive wind pressure on the underside of the slating.

Traditional materials, for example bituminous felt, fulfil those functions but are prone to cause condensation because of their relatively high resistance to water vapour.

Alternative vapour open materials - "breather membranes" - are now readily available and are recommended for all types of roof; they allow water vapour to disperse safely to atmosphere without the need for air movement beneath them. They are also much stronger and their use can result in a warmer, cleaner loft space and improved energy efficiency.

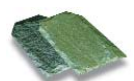



Handling and storage

- ❑ Burlington roofing slates are delivered stacked on edge in wooden crates. Slate is a dense, heavy material, provide good vehicular access and off-load using lifting tackle.
- ❑ Unload as close as possible to the roof to avoid excessive handling and handle with care to avoid damage.
- ❑ Store the crates on a firm even base and keep clean: crates may be stacked not more than two high.
- ❑ Once removed from the crate, slates should be stacked on edge on boards or battens, do not stack flat.
- ❑ Store all accessories in a safe, waterproof store.
- ❑ Store underlays as recommended by the manufacturer and protect from direct sunlight.
- ❑ Store battens and counterbattens on sufficient bearers to prevent sagging and twisting and keep them dry.
- ❑ Load slates onto the roof evenly distributed on both slopes simultaneously to avoid distortion of the roof structure.

Health and safety

Burlington roofing slates present no particular safety hazard when normal common sense is employed in storage, handling and fixing. Slate is an inert material and inherently safe if handled with due caution.

The edges of slates are rough and can cut if handled carelessly - wear gloves to protect your hands. When cutting and holing slates there is a risk from flying chips; wear safety goggles. Dust produced by dry machining contains silica which can be a long-term health hazard if inhaled in significant quantities for extended periods: use a suitable dust mask.

The main hazard in any roofing work is falling, especially in wet or windy weather and when working on wet surfaces. Roofers are advised to wear hard hats and safety harness when on a roof.

- ❑ Do not walk on slates. Use crawling boards, ladders, hooks, etc supported and anchored to prevent slipping or tipping. Use packing between boards and slates to avoid damage. Do not drag materials or tools across the roof.
- ❑ Do not rest access ladders against an eaves gutter: block out to clear the gutter and make secure. Ensure any ladder used to access a roof gable rests below the verge to ensure proper support and block out to clear any verge overhang.
- ❑ If a valley is used for temporary access to the roof ensure it is not damaged, wear soft shoes.

There are mandatory requirements governing the safe disposal of batten off-cuts if they contain toxic substances which could introduce an environmental hazard. See DoE waste management Paper No. 16: Wood Preserving Wastes.

Preparation

Slatting can be nailed to softwood battens or to softwood sarking boards. Battens and boards must be supported at each end and intermediately by at least three rafters, and nailed to every rafter; do not cantilever or splice battens between supports. Ends of battens and boards should be carefully square sawn and butt-jointed centrally on the face of a rafter.

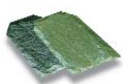



Installation

Observe the following general installation sequence when slating a roof:-

- 1** Sort random slates into batches of the same length (within 25mm). Determine the number of courses which may be made of each length.
- 2** Sort slates by size and thickness.
- 3** Hole slates to the correct gauge with the thicker end at the tail.
- 4** Lay the underlay and secure it with temporary battens or the counterbattens.
- 5** Batten out the roof to the correct gauge. Fix battens across at least three rafters and ensure they end on a rafter so square-cut ends butt together. Nail battens to every rafter.
- 6** Set out the slating at eaves taking account of verges, abutments and penetrations so as to reduce the amount of cutting required.
- 7** When laying patterns, use a chalk line vertically to mark the bond pattern onto the battens.
- 8** Start slating from the eaves and a verge; lay slates broken bond progressively to the ridge maintaining a raked working edge and extending the work sideways with each successive course.

- 9** Lay slates of equal thickness in any one course, using thicker slates towards the eaves and thinner slates towards the ridge.
- 10** For random slating, use the largest slates at the eaves and the smallest slates at the ridge, grading progressively up the roof slope.
- 11** Allow 3 - 4mm gap between neighbouring slates; fix each slate with two slating nails which should lie flush with the face of the slate.

Key points

- ❑ Keep the courses and laps to true and regular lines.
- ❑ When using randoms, make sure you have sufficient slates to complete an area before fixing the battens.
- ❑ Keep discarded nails, slate clippings, sawdust and debris out of the work; keep the underlay clean.
- ❑ Remove all debris trapped in valleys or gutters.
- ❑ Do not allow mortar to stain the face of the slates when bedding fittings in mortar.
- ❑ Treat leadwork with patination oil.

Specific sitework information is contained in the individual data sheets available from our web site or from Burlington. 

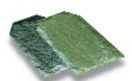



Technical references

Designers are recommended to study the following references on aspects of roofing design:-

BS 6399: Loading for buildings

- 6399-2:1997 Code of practice for wind loads

Describes how to assess wind loadings on buildings including the wind loading on roofs.

BS 5250:2002 Code of practice for control of condensation in buildings

Describes the way moist air behaves in buildings and gives recommendations on how to avoid damaging condensation within elements of construction including roofs.

BS EN 12056-3:2000

Gravity drainage systems inside buildings. Roof drainage, layout and calculation

Describes a method for assessing rainfall intensity and for calculating the sizes of gutters and downpipes.

BS 5534:2003 Code of practice for slating and tiling (including shingles)

Contains general guidance on designing to resist wind forces and covers the specification of ancillary items such as underlays, battens, mortar etc.

BS 8000: Workmanship on building sites

- 8000-6:1990: Code of practice for slating and tiling of roofs and claddings

Contains practical advice on aspects of site work.

Quality Assurance

The inherent quality of natural slate from the English Lake District is known and valued world-wide and at Burlington we have been working to the highest manufacturing standards for 150 years. Today, that means not only meeting, but substantially exceeding, the requirements of international Standards. Our roofing products are manufactured under the ISO 9002/BS 5750:Part 2:1987 quality system and carry the BSI Kitemark symbol of quality.

Prices and conditions of sale

Burlington roofing slates are sold subject to our standard conditions of sale, a copy of which is available on request. We will gladly provide you with current details of availability and lead times and will be happy to provide firm quotations for individual projects on the basis of drawings and/or Bills of Quantities.

Ordering, supply, delivery

Burlington roofing slates may be obtained only from Burlington Slate Limited; they are crated and palletted and delivery in the UK is normally by our own road haulage vehicles.

Technical services

We are always happy to provide technical advice on the use of Burlington roofing slates for new build or refurbishment projects. We offer in-depth project consultation and a range of support services including:-

- a technical advice line: call (01229) 889 665;
- estimating;
- details on AutoCAD;
- copies of relevant test results;
- product samples;
- help and advice on meeting national building regulations.

Web site

For up to date news and information on the worldwide use of Burlington roofing slates visit our web site at **www.burlingtonslate.co.uk**

Note

Recommendations as to methods, use of materials and construction details are based on the experience and knowledge of Burlington Slate Limited and on British Standards, they are given in good faith as a general guide to designers, contractors and manufacturers.

Different methods and techniques are traditionally adopted in other countries; in Scotland for example it is more usual to head nail slates onto wooden sarking boards.

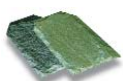

Minimum recommended laps for Burlington slates on various roof pitches

Sized slates	Slate size		Pitch	Moderate Exposure Less than 56.5 l/m ² per spell								Severe Exposure Equal or greater than 56.5 l/m ² per spell									
	(mm)	(inches)		20	22.5	25	28	30	35	40	45	75	20	22.5	25	28	30	35	40	45	75
	610	24		Headlap	A	A	91	82	77	67	60	54	54	A	A	A	104	98	85	76	69
560	22	A	A		91	82	77	67	60	54	54	A	A	116	104	98	85	76	69	69	
510	20	A	A		91	82	77	67	60	54	54	A	A	116	104	98	85	76	69	69	
460	18	A	A		91	82	77	67	60	54	54	-	-	116	104	98	85	76	69	69	
405	16	-	-		-	82	77	67	60	54	54	-	-	-	104	98	85	76	69	69	
355	14	-	-		-	82	77	67	60	54	54	-	-	-	104	98	85	76	69	69	
305	12	-	-		-	82	77	67	60	54	54	-	-	-	104	98	85	76	69	69	

A Minimum width restrictions apply, please contact Burlington for details

Patterns	Slate size		Pitch	Moderate Exposure Less than 56.5 l/m ² per spell								Severe Exposure Equal or greater than 56.5 l/m ² per spell									
	(mm)	(inches)		20	22.5	25	28	30	35	40	45	75	20	22.5	25	28	30	35	40	45	75
	610 x 355	24 x 14		Headlap	113	101	91	82	77	67	60	54	54	143	128	116	104	98	85	76	69
610 x 305	24 x 12	-	-		91	82	77	67	60	54	54	-	-	-	104	98	85	76	69	69	
560 x 305	22 x 12	-	101		91	82	77	67	60	54	54	-	128	116	104	98	85	76	69	69	
510 x 305	20 x 12	113	101		91	82	77	67	60	54	54	143	128	116	104	98	85	76	69	69	
510 x 255	20 x 10	-	-		91	82	77	67	60	54	54	-	-	116	104	98	85	76	69	69	
460 x 305	18 x 12	113	101		91	82	77	67	60	54	54	-	-	116	104	98	85	76	69	69	
460 x 255	18 x 10	113	101		91	82	77	67	60	54	54	-	-	116	104	98	85	76	69	69	
405 x 255	16 x 10	-	-		-	82	77	67	60	54	54	-	-	-	104	98	85	76	69	69	
405 x 205	16 x 8	-	-		-	82	77	67	60	54	54	-	-	-	104	98	85	76	69	69	
355 x 255	14 x 10	-	-		-	82	77	67	60	54	54	-	-	-	104	98	85	76	69	69	
355 x 205	14 x 8	-	-		-	82	77	67	60	54	54	-	-	-	104	98	85	76	69	69	
305 x 255	12 x 10	-	-		-	82	77	67	60	54	54	-	-	-	104	98	85	76	69	69	
305 x 205	12 x 8	-	-		-	82	77	67	60	54	54	-	-	-	104	98	85	76	69	69	

Randoms	Slate size		Pitch	Moderate Exposure Less than 56.5 l/m ² per spell								Severe Exposure Equal or greater than 56.5 l/m ² per spell									
	(mm)	(inches)		20	22.5	25	28	30	35	40	45	75	20	22.5	25	28	30	35	40	45	75
	1220 - 765	48 - 30		Blue Grey Headlap	A	A	91	82	77	67	60	54	54	A	A	A	104	98	85	76	69
700 - 560	28 - 22	A	A		91	82	77	67	60	54	54	A	A	A	104	98	85	76	69	69	
560 - 460	22 - 18	A	A		91	82	77	67	60	54	54	-	-	116	104	98	85	76	69	69	
560 - 305	22 - 12	-	-		-	82	77	67	60	54	54	-	-	-	104	98	85	76	69	69	
460 - 355	18 - 14	-	-		-	82	77	67	60	54	54	-	-	-	104	98	85	76	69	69	
460 - 255	18 - 10	-	-		-	82	77	67	60	54	54	-	-	-	-	-	85	76	69	69	
355 - 255	14 - 10	-	-		-	82	77	67	60	54	54	-	-	-	-	-	85	76	69	69	
610 - 460	24 - 18	Westmorland Green Headlap	A	A	91	82	77	67	60	54	54	-	-	A	104	98	85	76	69	69	
610 - 305	24 - 12		-	-	-	82	77	67	60	54	54	-	-	-	104	98	85	76	69	69	
510 - 305	20 - 12		-	-	-	82	77	67	60	54	54	-	-	-	104	98	85	76	69	69	
460 - 305	18 - 12		-	-	-	82	77	67	60	54	54	-	-	-	104	98	85	76	69	69	
460 - 230	18 - 9		-	-	-	-	77	67	60	54	54	-	-	-	-	-	-	76	69	69	
305 - 230	12 - 9		-	-	-	-	77	67	60	54	54	-	-	-	-	-	-	76	69	69	

A Minimum width restrictions apply, please contact Burlington for details

Note: Minimum width of random slates is 190mm or 7.5"

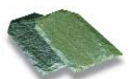

Approximate coverage and weight of slating based on 77mm headlap*

Sized slates	Slate size		Cover m ² per tonne		Weight kg per m ²		Batten length in m per m ²	N ^o slates per m ²	Battening gauge (mm)	Holing gauge (mm)
	(mm)	(inches)	Westmorland Green	Blue Grey	Westmorland Green	Blue Grey				
560	22	18.00	22.00	55.34	44.51					
510	20	18.00	22.00	53.33	44.49					
460	18	17.50	22.00	53.02	44.65					
405	16	17.50	22.00	53.81	45.20					
355	14	17.00	22.00	54.83	46.31					
305	12	17.00	22.00	55.79	47.26					

Patterns	Slate size		Cover m ² per 1000 slates	Weight kg per m ²		Batten length in m per m ²	N ^o slates per m ²	Battening gauge (mm)	Holing gauge (mm)
	(mm)	(inches)		Westmorland Green	Blue Grey				
			610 x 355			24 x 14	94.60	56.60	44.15
610 x 305	24 x 12	81.28	56.60	44.15	3.75	12.30	267	359	
560 x 305	22 x 12	73.65	55.34	44.51	4.14	13.57	242	334	
510 x 305	20 x 12	66.03	53.33	44.49	4.62	15.14	217	309	
510 x 255	20 x 10	55.20	53.33	44.49	4.62	18.11	217	309	
460 x 305	18 x 12	58.40	53.02	44.65	5.22	17.12	192	284	
460 x 255	18 x 10	48.83	53.02	44.65	5.22	20.47	192	284	
405 x 255	16 x 10	41.82	53.81	45.20	6.10	23.91	164	256	
405 x 205	16 x 8	33.62	53.81	45.20	6.10	29.74	164	256	
355 x 255	14 x 10	35.45	54.83	46.31	7.19	28.20	139	231	
355 x 205	14 x 8	28.50	54.83	46.31	7.19	35.08	139	231	
305 x 255	12 x 10	29.07	55.79	47.26	8.77	34.39	114	206	
305 x 205	12 x 8	23.37	55.79	47.26	8.77	42.78	114	206	

Randoms	Slate size range			Cover m ² per tonne	Weight kg per m ²	Batten length in m per m ²	N ^o slates per m ²	Battening gauge	Holing gauge
	(mm)	(inches)							
	1200 - 765	48 - 30	Blue Grey	20.00	60.03	2.20	-	-	-
700 - 560	28 - 22	20.00		44.73	3.58	-	-	-	
560 - 460	22 - 18	20.00		44.55	4.62	-	-	-	
560 - 305	22 - 12	20.00		44.88	5.67	-	-	-	
460 - 255	18 - 10	20.00		46.12	7.19	-	-	-	
355 - 255	14 - 10	20.00		47.26	8.77	-	-	-	
610 - 460	24 - 18	Westmorland Green	18.00	55.55	4.37	-	-	-	
610 - 305	24 - 12		17.75	56.34	5.22	-	-	-	
510 - 305	20 - 12		17.50	57.14	5.67	-	-	-	
460 - 305	18 - 12		17.00	58.82	6.60	-	-	-	
460 - 230	18 - 9		17.00	58.82	7.46	-	-	-	
305 - 230	12 - 9		17.00	58.82	10.64	-	-	-	

Note: These figures exclude any allowance for waste and cutting on site. All details subject to change based on Burlington Slate Q.A. Manual.

* For each 12.5mm (.5 inch) variation in the headlap of the slates the approximate coverage and weight will vary by the following percentages:

610	560	510	460	405	355	305	255	Slate size (mm)
24	22	20	18	16	14	12	10	Slate size (inches)
2.33	2.57	2.87	3.24	3.78	4.46	5.43	6.94	%

The variation in the coverage and weight of Random slates should be calculated using the average length of the slates.



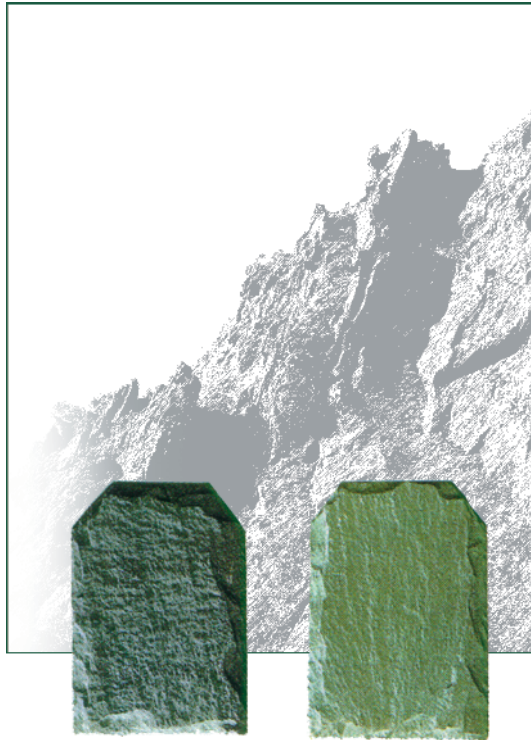

Burlington roofing slates; available in Blue/Grey and Westmorland Green

Burlington Slate Limited

Head Office

Cavendish House, Kirkby-in-Furness, Cumbria, LA17 7UN, England
Telephone: 01229 889 661 • Fax: 01229 889 466
e-mail: roofing@burlingtonstone.co.uk

London Office

15 Queen Anne's Gate, London SW1H 9BU, England
Telephone: 020 7976 7676 • Fax: 020 7976 0033

Web Sites

www.burlingtonslate.com
www.burlingtonstone.com
www.the-fifth-element.com
www.burlingtonlandscape.co.uk