

Installation Recommendations

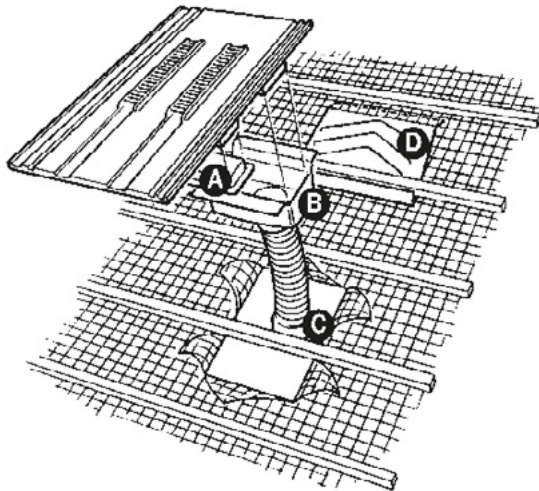

Soil Pipe Adaptor Kit. Code HD ILSPA

- A. Blanking Plug
- B. Vent Adaptor
- C. 100mm Flexible Hose
- D. Optional Extra - Moisture Diversion Plate Code IL/DP

Fitted flush with the slates at 2m centres, the ventilator will provide an equivalent airflow to a continuous 5mm high level gap, and should be fitted in conjunction with the appropriate Danelaw eaves ventilation products. As an alternative to an eaves ventilation system the vents should be fitted at 1m centres to achieve the equivalent of the requirement for a 10mm continuous gap at eaves level.

Underlay Preparation

The unique twin venting spigots require two rectangular apertures to be cut into the underlay. This should be carried out in accordance with the illustration overleaf, in order to deflect and prevent water and debris penetration through the underlay, thus maintaining the integrity of the roof underlay.

Sark Board Fixing

When fitting flush fit slate ventilators to roof constructions that utilise sarking boards, the surrounding slates should be trimmed as per the instructions overleaf. The underlay should be cut to form a 205mm wide x 290mm deep opening by cutting the diagonals of the rectangle. The triangular flaps of the

underlay are then folded back and tacked to the sarking to help maintain the integrity of the roof.

The sarking board below is then cut out to match the aperture in the underlay to enable the spigots on the ventilator to pass through into the roof void. Care must be taken at this stage to trim the opening neatly and accurately to fit the ventilator spigots and not create excess space around them, which may impair the integrity of the roof cover. The vent may now be fitted and the other slates trimmed around.

Soil Ventilation and Mechanical Extraction

When using the ventilator for either soil ventilation or mechanical extraction it is advisable to first of all fit the adaptor kit, and the blanking plug to the smaller of the two spigots to prevent back-venting. Both ventilator spigots should be left open if ventilation only is required.

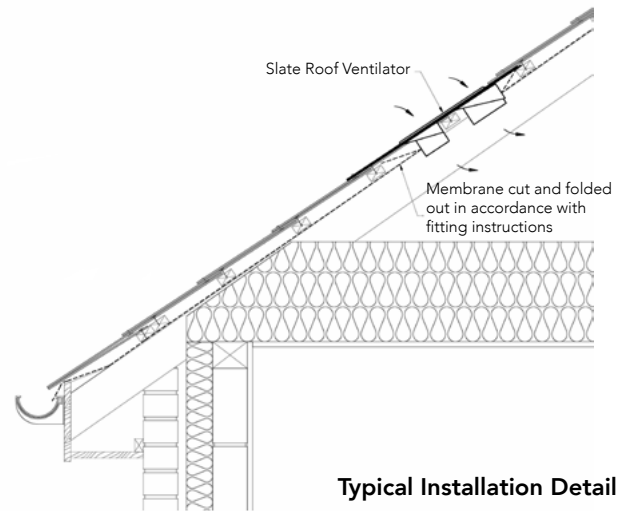

Typical Installation Detail

Flush Fitting Ventilators to suit two slate sizes:
600 x 300mm - Code **HD ILSRV10/24**
500 x 250mm - Code **HD ILSRV10/20**

Slate Configuration for HD ILSRV10/20

Ventilator size 565 x 290mm

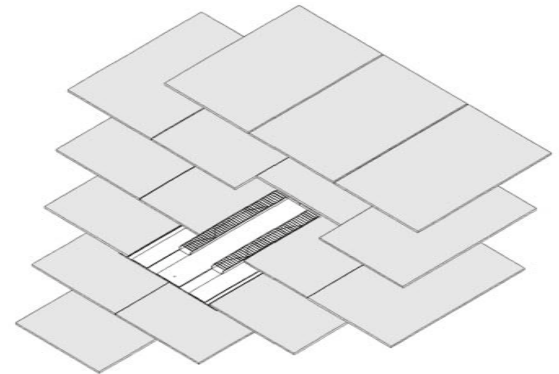

Adjacent slates overlap ventilator outer flanges

Slate Configuration for HD ILSRV10/24

Ventilator size 615 x 300mm

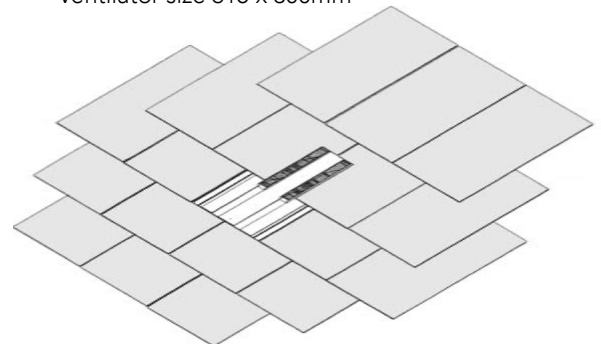

Adjacent slates abut ventilator

Installation Recommendations and Slate Cutting Templates

70mm

SLATE CUTTING TEMPLATE

1

This template provides the cut-outs required for the TOP SLATES positioned above the ventilator

TOP SLATES

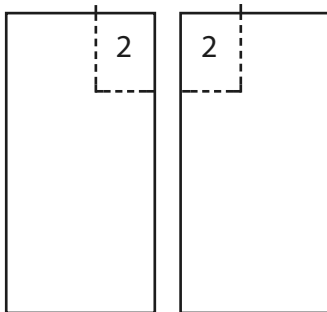
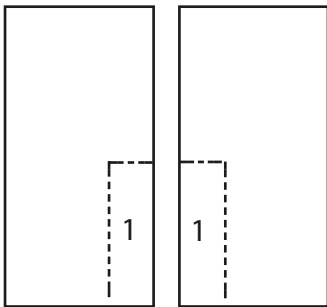

BOTTOM SLATES

Approximate cut lengths for 600 x 300mm and 500 x 250mm size slates:

Headlap	Cut Length
100mm	250mm
75mm	240mm

1. Cut the TOP slates using cutting template.
2. Cut the BOTTOM slates using cutting template
3. Mark and cut the underlay. When folding the top triangular shape of the smaller rectangle aperture outwards this should be secured by tacking it to the batten. Fold out all the triangular shaped flaps outwards and back under the ventilator to deflect and prevent water and debris penetration through the underlay. Ensure that the snug fit to both ventilator spigots is achieved.
4. For soil ventilation and mechanical extraction make sure that the blanking plug provided is fitted to the smaller spigot **before**.

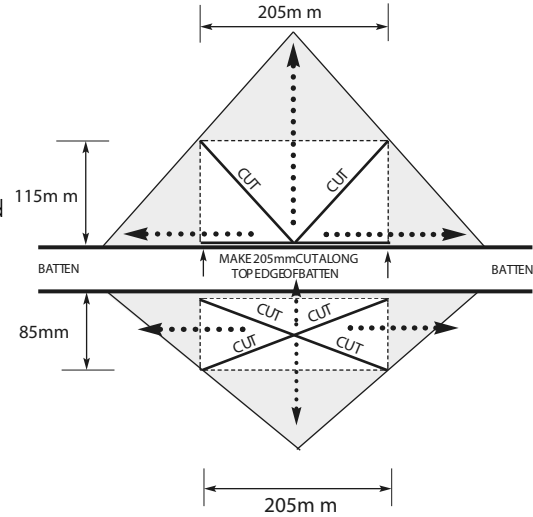

UNDERLAY CUTTING KEY

Cut Lines	—————
Fold Lines	- - - - -
Flap Directions>

5. Fit the ventilator as you would a normal slate. When using either natural or man-made slates, secure the tail of the ventilator using a copper disc river through the hole provided.
6. An additional moisture/debris diversion plate may be fitted if required.

CUT LENGTH WILL VARY ACCORDING TO HEADLAP

140mm

102mm

SLATE CUTTING TEMPLATE

2

This template provides the cut-outs required for the BOTTOM SLATES positioned below the ventilator.