

FIXER

FLAT ROOFING



EPDM

Installation guide

FIELD INSTALLATION GUIDE



FLAT ROOFING

CONTENTS

General Information & Precautions	3
Tools, Equipment & Roof Surface Preparation	4

Membrane Installation

Installation of FIX-R EPDM Roofing	5/6
Base Tie-in Detail	7/8
Bonding Adhesive	9
Pipes/Penetrations in Membrane	10
Skylights & Chimneys	10
Perimeter Wall & Vertical Terminations	11
76mm Seam Tape	12
152mm PS Cover Strip	13
228mm PS Uncured Flashing	14

Pressure Sensitive Details

T-Joint Cover Patch	15
Internal Corner Details	16
External Corner Details	17
Prefabricated Pipe Boot	18
Pipe & Penetration Flashing	19

Roof Outlets/Drains

Anti-Back-up 68mm Outlet	20
Fix-R EPDM Top Drain Outlet	21
Angled Roof Drain Outlet	22
On-site Fabricated Outlet	23
EPDM to BUR Join	24

Perimeter Terminations

Sure Edge PVC Gutter Trims	25
Sure Edge PVC Kerb Trims	26/27

General Information

This Rooftop Guide has been designed to give the user a GENERAL overview of the application of a Fix-R EPDM roof. This Guide is intended as broad reference aid and is not intended or meant to be all-inclusive. It should be used in conjunction with Fix-R EPDM CAD details.

Precautions

If the bonding adhesive is not allowed to properly dry, gas bubbles or blisters may form under the membrane sheet. These bubbles or blisters may subside over time.

Due to solvent flash off, condensation may form on freshly applied adhesive when the ambient temperature is near the dew point. If condensation develops, possible surface contamination may occur and the application of adhesive must be discontinued. Allow the surface to dry and when conditions allow apply a thin refresher coat at a coverage rate that is approximately half of the normal coverage rate when re-adhering a previously coated surface.

Extreme care must be exercised when working on ladders, roofs, or at elevations above ground. If used as an emergency repair to a roofing system, contact the roofing system manufacturer for compatibility and to ensure compliance with terms and limitations of the warranty.

Surface can be slippery when wet, damp, or frost covered.

Do not stretch the product during installation.

Do not expose product to temperatures in excess of 82°C (180°F).

This product is not intended for use where roof top traffic or activity is anticipated without a protective layer installed on its surface.

THIS INFORMATION AS WELL AS INFORMATION CONTAINED IN THE MATERIAL SAFETY DATA SHEET AND ON PRODUCT PACKAGING MUST BE REVIEWED PRIOR TO STORAGE, HANDLING OR USE OF THESE PRODUCTS.



FLAT ROOFING

Tools & Equipment

- 50mm hand roller
- Hammer
- Hook blade knife/scissors
- Pencils
- 228mm medium nap roller on pole
- Chalk line
- Safety glasses
- Tape measure
- 50-76mm brushes
- Stirrers for adhesive and primer
- Solvent resistant gloves
- Soft bristle broom
- Caulk gun
- Scrubbing pads for EPDM primer

Roof Surface Preparation

The Fix-R EPDM fully-adhered system will adhere to wood, wood fibreboard and lightweight concrete. This product may NOT be applied to polystyrene insulation. Fix-R EPDM WBA Adhesive is intended for bonding to timber surfaces only. Other surfaces must be bonded with Fix-R EPDM Bonding Adhesive. Roofs over 100m² must also be installed with Bonding Adhesive.

Ensure the roof surface is clean, free of dust, dirt, rust, oil, grease, and loose material. The roof surface must be dry.

This product will not adhere to wet or damp surfaces. Trapped moisture may vaporise and negatively affect the performance of this product.

Good roofing practice dictates that ponding water be avoided. The roof surface should have a positive slope of at least 1 in 80 to prevent ponding water conditions. Before starting please consult the "Precautions" section at the beginning of this manual.

MEMBRANE INSTALLATION

Installation of FIX-R EPDM Roofing

- Unroll Fix-R EPDM membrane over the substrate so that the sheet is in the desired position and is wrinkle free.
- Fix-R EPDM WBA Adhesive is intended for bonding to timber surfaces only. Other suitable surfaces must be bonded with Fix-R EPDM Bonding Adhesive. Roofs over 100m² must be installed with Bonding Adhesive.
- It is essential for Fix-R EPDM membrane is allowed to relax prior to adhering. The time required for this will vary depending on weather conditions.
- Cut the membrane to length if required, and position the sheet to achieve an overhang off the roof of at least 76mm (3") for both the length and width.
- RUSS (Reinforced Universal Secure Strip) should be installed wherever the membrane turns up through an angle change.
- Fold the sheet back to expose one-half of the deck; take care to avoid wrinkles.



FIX-R

FLAT ROOFING

- Open and thoroughly stir the Fix-R EPDM WBA Adhesive or Bonding Adhesive. Using a medium nap paint roller apply the adhesive to the substrate. If using Bonding adhesive, the rear of the membrane must also be coated.
- Adhesive must be applied to 100% of the surface in an even coat without globs or puddles. WBA adhesive can alternatively be applied in a thin coat to both the membrane and substrate.
- Roll the sheet onto the coated substrate avoiding wrinkles by rolling the middle of the sheet first. Immediately after rolling the sheet into the adhesive, broom or roll the membrane sheet to achieve maximum contact.
- DO NOT apply excessive pressure to cause the membrane to wrinkle.
- Repeat the application of Fix-R EPDM WBA adhesive for the other half of the Fix-R EPDM membrane.

NOTE: DO NOT APPLY WBA or BONDING ADHESIVE TO ANY SEAM AREAS.



Base Tie-in Detail

In common with most single ply material EPDM will, overtime, try to shrink by up to 10%. Base tie-in's control membrane movement and stop membranes pulling away from perimeters and angle changes. Further movement is accommodated by membrane flexibility.

Fix-R EPDM PS RUSS (Reinforced Universal Secure Strip) is used to mechanically secure EPDM membranes to the substrate.

152mm RUSS has cured EPDM splice tape adhesive laminated along one edge. It can be installed to horizontal or vertical surfaces in conjunction with Seam Fastening Plates.

Seam Fastening Plates are used with RUSS to securely clamp it to the surface at 300mm centres; these must be used in conjunction with the appropriate fasteners for the substrate.

Fix-R EPDM should be mechanically secured wherever an inside angle of greater than 15° occurs. RUSS can be used to achieve this.

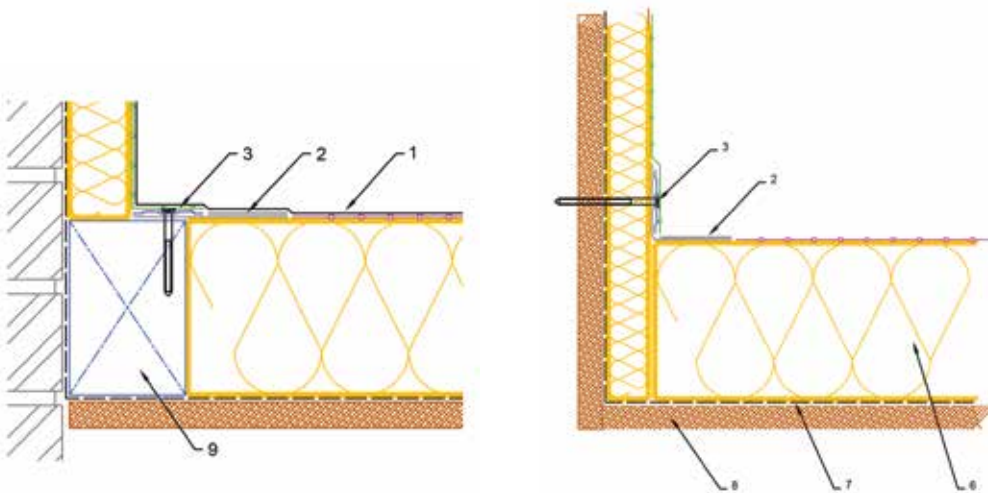

All unreinforced EPDM's and most other single ply membranes produced, regardless of manufacturer, require mechanical securement to eliminate shrinkage and to install in accordance with manufacturers specifications. This is standard practice.



- 1** Mechanically fasten RUSS to decking or vertical upstand at 300mm centres. The PS section must face main field area.

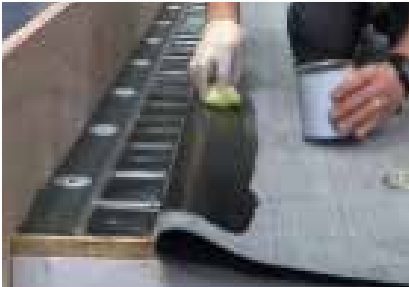

- 2** Apply Fix-R EPDM Primer to target area on the underside of the EPDM membrane that will come into contact with the 76mm PS tape on the RUSS.



- 3** Once the primer is dry remove the protective strip from the PS tape on the RUSS. Guide primed membrane onto the PS tape. Avoid wrinkles or air pockets. Smooth by hand then roll with hand roller.



- 4** Once secured to the RUSS finish the upstand by using Bonding Adhesive to the remainder of RUSS, upstand and membrane.

Bonding Adhesive

Fix-R EPDM Bonding adhesive is used on all surfaces on the roof area greater than 15°, e.g. wall upstands, batten and sky light edges. This adhesive will work on porous and non-porous surfaces, providing they are clean and dry. The Bonding Adhesive will enable tight angles to be formed quickly and easily.



- 1** Apply Bonding Adhesive to both substrate and reverse of the Fix-R EPDM membrane.



- 2** Once the adhesive has become touch dry with no wet puddles, mate the two surfaces together. Leave no voids between the Fix-R EPDM membrane and the receiving surface.



- 3** Applying positive pressure to the membrane work the membrane up the upstand to the desired height. These areas should be rolled to achieve a strong bond between membrane and substrate.

Pipes/Penetrations in Membrane

When laying out the field sheets and a pipe or penetration is encountered, roll the folded membrane to the pipe. Be sure to maintain the proper alignment of the sheet with the roof edge, wall, and seams.

- Make a straight cut from the pipe to the nearest edge of the field sheet.
- Cut a hole to match the diameter of the pipe and roll the field sheet around the pipe.
- Check the final position off the sheet. Fold the membrane back and begin the bonding procedure.
- Once the field sheet has been glued and broomed into place, apply a Fix-R EPDM 152mm (6") wide Semi-cured Cover Strip over the entire cut in the field sheet from the pipe to the outside edge of the sheet.

See the "Prefabricated Pipe Boot" section of this manual for further information on finishing this detail.

Skylights & Chimneys

- Prior to applying the adhesive, and while maintaining proper sheet alignment with walls, perimeter edges and other protrusions, unroll the membrane up to the base of the unit.
- Measure the width and depth of the unit and transfer the corresponding dimensions onto the folded membrane. Draw an "X" inside the box. Cut the "X" mark and from one corner cut a straight line to the nearest edge of the membrane.
- Roll the membrane around the unit, leaving a triangle of membrane turning up each one of the four (4) sides.
- After all cuts are made and the membrane has been correctly positioned, fold the membrane back and begin bonding procedures.
- After the field area is complete, bond the triangles up the sides of the unit (chimney, skylight, etc.). Take care to bond the membrane into the angle change so that the membrane is completely adhered.
- After the field sheet has been glued and broomed into place, apply a Fix-R EPDM 152mm (6") Cover strip over the entire cut in the field sheet from the curb to the end of the sheet.

Perimeter Walls

It is possible to seal abutments using a continuous sheet of membrane from the field area, provided mechanical securement is used.

The membrane must extend up the wall a minimum of 150mm and an appropriate termination used.

Vertical Termination

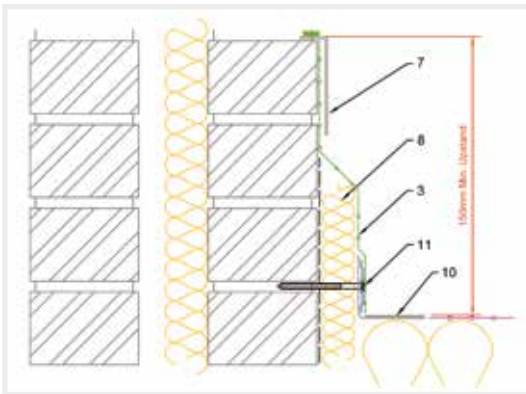

Wall Trim

- After the desired flashing height is attained and the membrane has been adhered.
- Insert the trim into the previously cut chase and mechanically fix into place using RB fasteners at a max spacing of 500mm.
- Apply a bead of Lap Sealant along the top of the trim and wall.

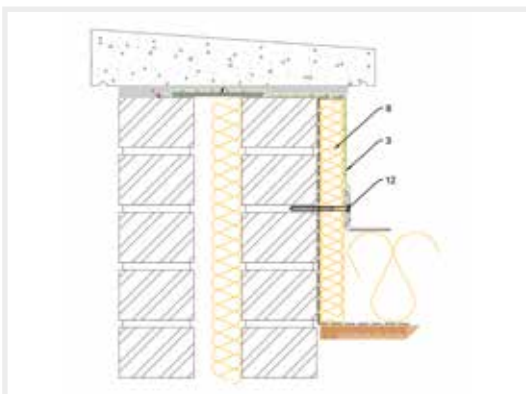

Coping Stone

- Lay Fix-R EPDM across the wall. Use Bonding adhesive and apply a bead of water cut off mastic under the outside edge of membrane and compress.
- Apply an even bed of mortar over the membrane.
- Lay suitable coping stones ensuring they have sufficient over hang and drip channels.

76mm Seam Tape

The membrane should be positioned so that the width of the seam is 76mm (3"). Mark a line 5mm (1/4") from the leading seam edge.



- 1** Fold the top sheet back to expose the seam area. Using a scrubbing pad apply the Fix-R EPDM Primer to the seam area. Apply the primer past the seam edge to the line. Fix-R EPDM Primer must be dry before application of PS tapes.

NOTE: If the EPDM membrane is contaminated with dirt, etc., clean the seam area.



- 2** Using moderate pressure set the Seam Tape into place to keep air from being trapped under the tape. Unroll the 76mm PS Tape along the length of the seam, aligning the tape (not the clear backing) along the chalk line. Care must be taken not to get any bubbles or wrinkles in the tape.



- 3** Lay the top membrane onto the Seam Tape. Pull away the clear backing from the tape at 45° degrees to the seam. While removing the poly backing, apply pressure across the seam, from the back to the leading edge. Roll the seam at right angles to the seam direction, & along it.

152mm PS Cover Strip

When butt jointing of Fix-R EPDM membrane or seaming to a metal drip or similar a 152mm cover strip is used.



- 1** Ensure there is no gap between the membrane when butt jointing. The 152mm tape should be centrally located over the joint.



- 2** Apply Fix-R EPDM Primer to the area to be seamed. Apply primer 80-100mm either side of the join of the EPDM sheets.



- 3** Once the Fix-R EPDM Primer has dried, peel back 150mm of the poly backing and press the PS tape into the primed area. Once the tape is held in position, peel back the poly backing and smooth the tape into the primed area. Progress along the seam.



- 4** Once the entire length of tape is applied to the seam, roll across the 152mm tape with hand roller. Where 152mm tapes intersect other tapes, 228mm PS Uncured Flashing cover patches must be applied.

228mm PS Uncured Flashing

This tape is used for any detail work necessary on the roof. It has the ability to mould to almost any shape and will adhere to most surfaces, provided the surface is clean, dry, and correctly primed with the HP250 primer.

- To seal pipes, penetrations, corners and other details.
- Adaptable to irregular shapes and surfaces.
- Self-curing membrane.

IF 228mm PS UNCURED FLASHING MAY BE SUBJECTED TO SUBMERSION OR HIGH FLOW OF WATER, ALL EDGES SHOULD BE PROTECTED WITH CARLISLE LAP SEALANT. LAP SEALANT HELPS TO KEEP WATER FROM INFILTRATING BETWEEN THE FLASHING PLY AND THE TAPE PLY BEFORE THE FLASHING HAS FULLY CURED ON THE ROOF.

Typical details are shown on the following pages.

PRESSURE SENSITIVE DETAILS

T-Joint Cover Patch

A T-Joint is formed when two sheets of membrane form a seam that travels under, or over, a third section. The centre of the “T” is where the three sheets intersect.

- Use Fix-R EPDM Uncured Flashing to form T-Joint patches. T-Joint patches should be at least 152mm (6”) x 152mm (6”).
- Apply primer to membrane surface before applying T-Joint patches.

NOTE: All T-Joint Patches should be thoroughly rolled with a steel or silicone hand roller.

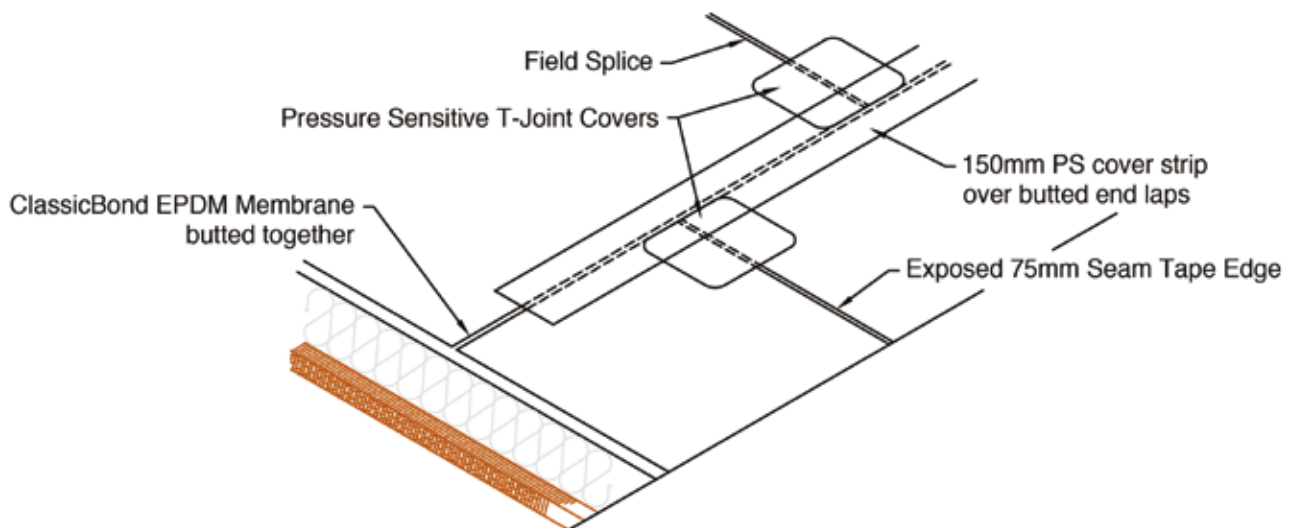

Internal Corner Details



- 1** Form excess membrane into neat flap. Cut back to leave a 76mm wide flap. Apply Fix-R EPDM Primer to the front & back of the flap and to the membrane on the wall. Fix-R EPDM Primer must be allowed to dry before application of PS tape.



- 2** Cut an appropriate size piece of 228mm PS Uncured Flashing (min. 50mm wider than the flap of membrane), press the flap back to the upstand and install the uncured flashing tape.



- 3** Roll the taped area with hand roller once installed.

External Corner Details

- 1** Cut the Fix-R EPDM membrane at 45° to allow the membrane to run around the corner and create both upstands. Bond in place with Fix-R EPDM Bonding Adhesive. Cut a section of 228mm PS Uncured Flashing to a min. 76mm onto deck and 50mm past angled cut in membrane.



- 2** Apply Fix-R EPDM Primer to the marked area to be taped and allow to dry. The area must be clean and dry before application of primer, apply primer to membrane and to upstand substrate. Fix-R EPDM Primer must be allowed to dry before application of tapes.



- 3** Start installing the tape from the top point. Work the tape down upstands first and into the bottom angle change.



- 4** Work the tape onto the deck around the corner and smooth out and roll the entire flashing with hand roller.

Prefabricated Pipe Boot



- 1** Cut the Fix-R EPDM PS Pipe Seal above the raised “rib” one size smaller than the pipe diameter. DO NOT CUT THROUGH THE RIB. Pull pipe seal over pipe until base flange is in contact with the Fix-R EPDM membrane.



- 2** Once in position clamp the seal to the pipe with the supplied metal clamp and mark around the base of the seal to give a line to prime up to. Pull pipe seal upwards on pipe to expose the membrane and apply Fix-R EPDM Primer to the EPDM deck membrane.



- 3** Pull pipe seal back down over pipe and into position. Remove poly backing from the tape and with hand pressure press tape onto primed area. Roll splice area with a hand roller

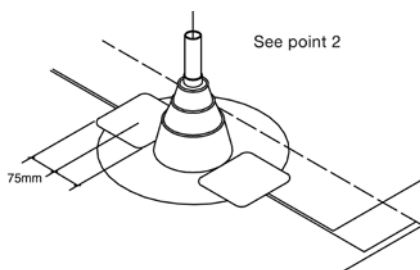

Apply Fix-R EPDM uncured T-Joint Patches where pipe seal intersects a field splice.

NOTE: Temperature of the pipe must not exceed 82°C (180°F)

Pipe & Penetration Flashing

To fabricate a pipe boot or flashing for other penetrations follow the procedures below using Fix-R 228mm PS Uncured Flashing.

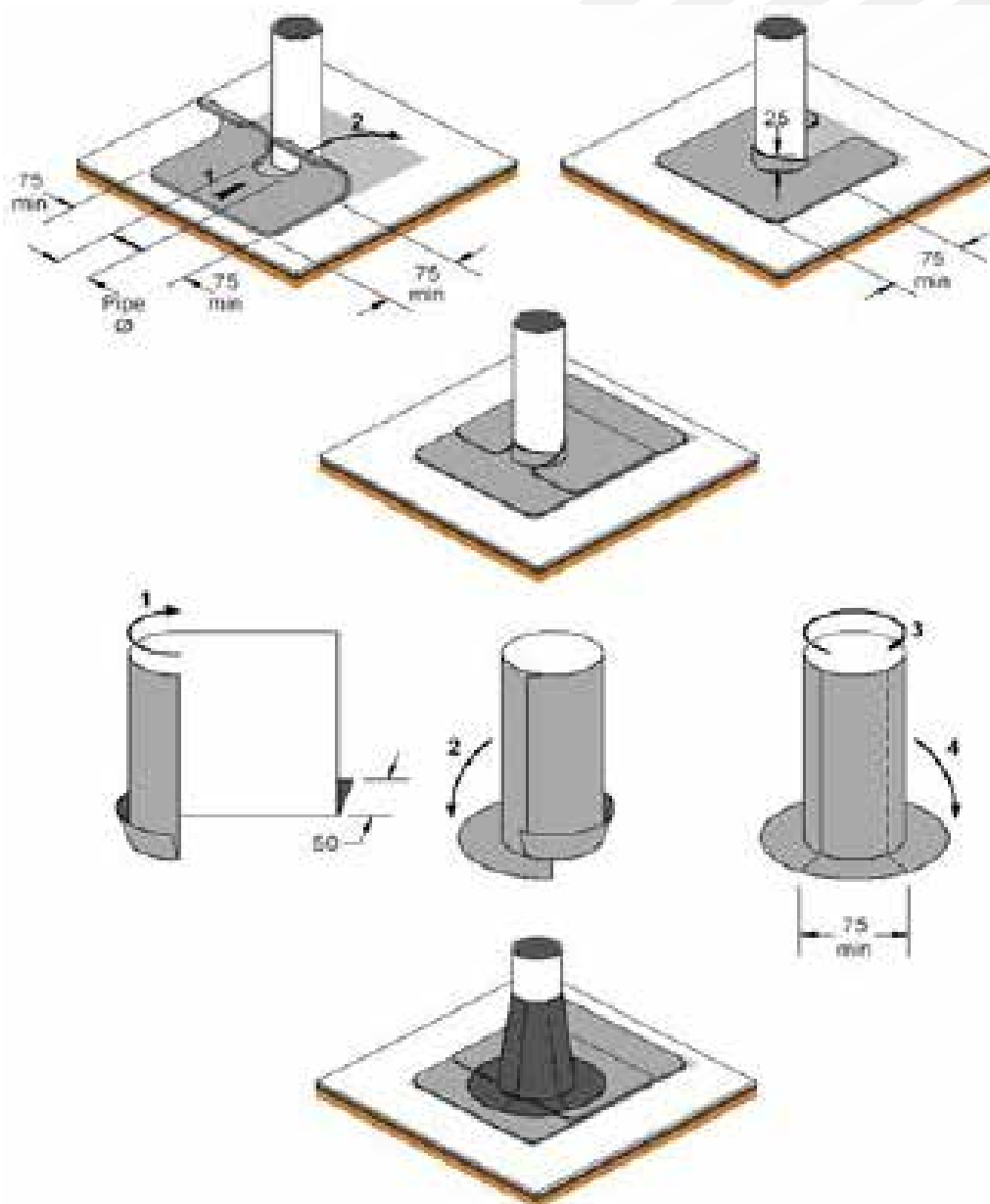

ROOF OUTLETS/DRAINS

Internal Drain

There are two basic methods for sealing to an internal drain. Fix-R EPDM Pre-made outlets of various types can be used for standard outlets or an on-site method may be used for non-standard outlets.

Anti-Back-up 68mm Outlet

These are 68mm roof outlets designed to be inserted into a standard rainwater down pipe. The outlet is fitted with a seal to achieve a watertight join. The outlet is sealed to the membrane using 228mm PS Uncured Flashing. A Leaf grate for this outlet is also available.



- 1** Cut the outlet flange back to leave a min. 50mm to deck. Cut the membrane back to meet the perimeter of the outlet head. Secure the outlet to the decking and apply Fix-R EPDM Primer to the head of the outlet and to the EPDM membrane.



- 2** Apply the 228mm PS Uncured Flashing to the primed area. Once fitted cut a small section from the centre of the tape out to expose the outlet opening and press the remaining tape down into the outlet. Roll the entire flashing with a 50mm hand roller.



- 3** Finally install the leaf grate to complete the outlet.

Fix-R EPDM Top Drain Outlet

110mm flat roof outlets allow high water flow where required.



- 1** Fit the outlet into the roof before installing the membrane; ensure the outlet has the yellow protective cap installed. Install the Fix-R EPDM membrane to the roof and over the outlet. Place cutting guide over the pin and cut round the circular plate.



- 2** Remove the circular section of membrane and the yellow protective cap from the outlet.



- 3** Insert a bead of Fix-R EPDM Water Cut Off mastic between the underside of the membrane and the top flange on the outlet. Screw in the clamping ring till it's completely tightened. Use the two tightening lugs to apply leverage to the ring.



- 4** Install the leaf grate into the three locating tabs.

Angled Roof Drain Outlet

For roofs designed with horizontal drains to go through walls and pitched roofs. The Fix-R EPDM Angled Roof Drain is fitted to the deck and sealed to the membrane using 228mm PS Uncured Flashing.



- 1** Install outlet into parapet wall before installing EPDM membrane. Install Fix-R EPDM membrane over the outlet with Fix-R EPDM Bonding Adhesive. Cut the membrane away from outlet opening by 25mm. Apply Fix-R EPDM Primer to the membrane, outlet face and into the outlet pipe.



- 2** Install 228mm PS Uncured Flashing to the outlet. This should be large enough to join onto the membrane by a minimum of 50mm. Cut a 30mm diameter circle from the middle of the tape. Mould the tape into the outlet pipe. Cut a second section of Uncured Flashing 100mm wide. Prime pipe and apply this to outlet.



- 3** Once the second section of tape is installed, complete by inserting the leaf grate into the outlet.

On-site Fabricated Outlet

For non-standard outlet design

This method uses just the 228mm PS Uncured Flashing to seal the membrane to the outlet pipe.

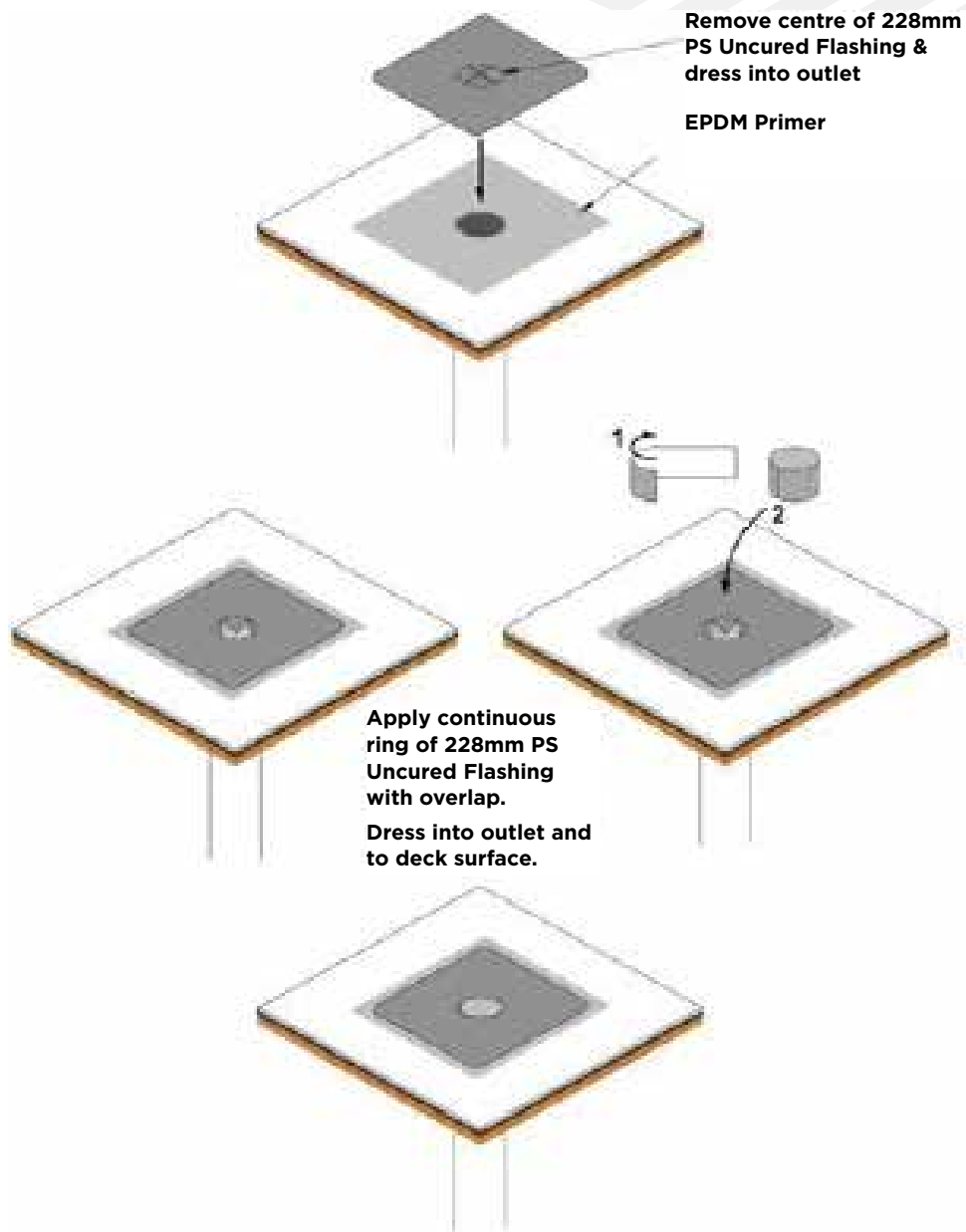

EPDM to BUR Join

There are two alternate methods to be used when the new Fix-R EPDM roof joins directly onto a neighbouring flat roof.

The diagram below shows a cold termination and simple guidelines to follow in the planning stage of the roof.

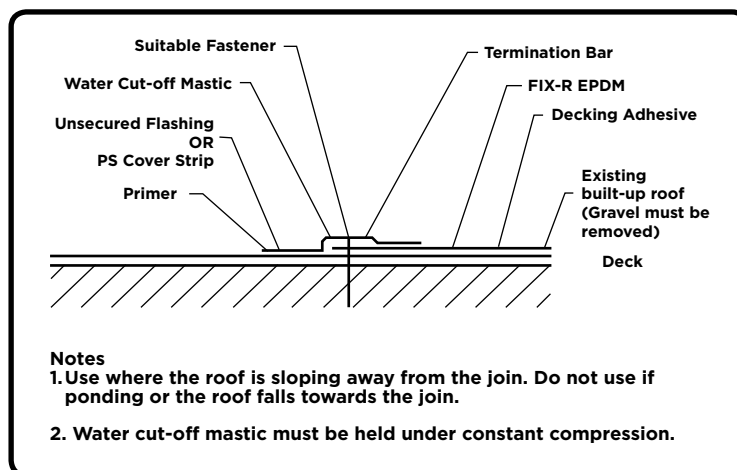
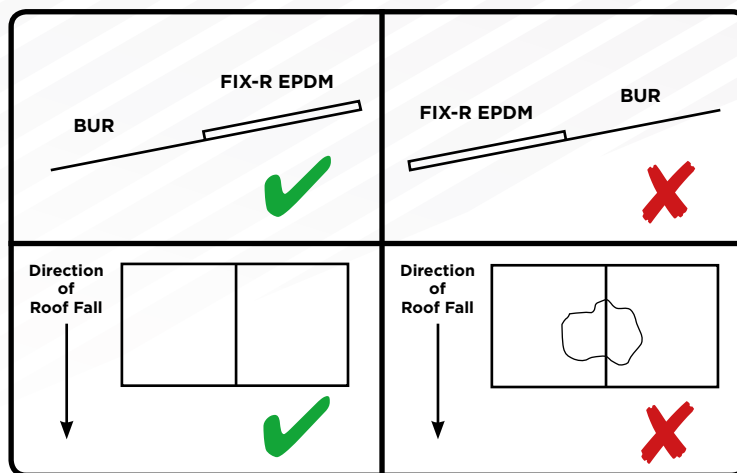

PERIMETER TERMINATIONS

Sure Edge PVC Gutter Trims

Offering a fast simple, good looking finish to the flat roof system. See more at www.sureedge.co.uk

Gutter System

This is available in two options, standard and built in batten back plate. The standard requires a timber batten to be installed first then the back plate fixed to it. The "Built in Batten" doesn't require the extra timber batten.

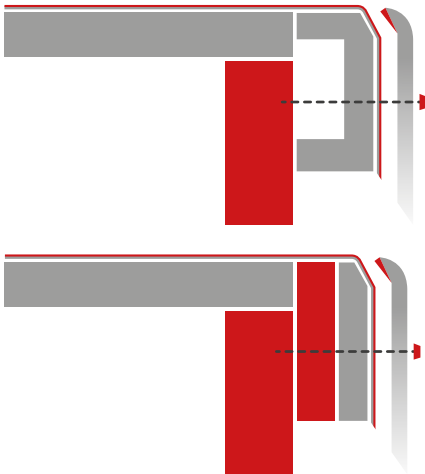

- Fix the 25mm x 40mm back plate to the fascia at the edge of the roof.
- Allow minimum 50mm Fix-R EPDM membrane over the back plate.
- Position the front plate with foam seal to clamp the membrane between the 2 sections and fully fix into place with supplied fixings.
- Between lengths allow 2.5mm expansion joint for each trim.

Note: In areas of high wind, exposed areas and high buildings additional fixings between predrilled holes is recommended.

Gutter Trim Joiner

Install joint covers by hooking the joiner under the bottom the front plate and clipping the top over.



Gutter Corners

External

- Apply the adhesive to one side of the corner
- Push down into position and hold till adhesive is set

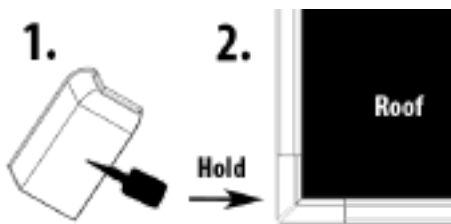

Internal

- Apply the adhesive to one side of the corner
- Push down into position and hold till adhesive is set.

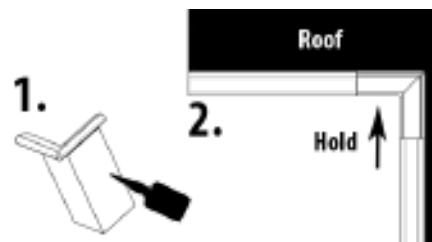

Sure Edge PVC Kerb Trims

Used to create upstand and edge trim in one component.

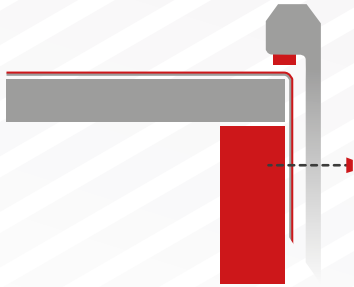

- Lay membrane and allow minimum 50mm overhang.
- Ensure membrane is clean, position edge trim and firmly push down to compress foam seal by min. 30% & max. 50%.
- Fix trim into place using supplied fixings.
- Between lengths allow 2.5mm expansion joint for each trim.

Note: If a secure fixing cannot be achieved a timber fixer should be fitted to the vertical edge of the roof. In areas of high wind, exposed areas and high buildings additional fixings between predrilled holes is recommended.

Kerb Joiner

Install joint covers by hooking the joiner under the front plate and clipping the top over.

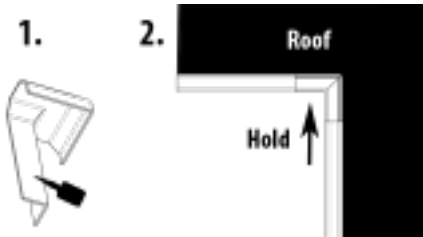

Internal Corner

- Mitre the trims so they fit together with foam seal compressing between the two trim ends.
- Apply adhesive to one side of the corner.
- Fit over trims and hold in place till set.

External Corner / Stop End

This universal corners is designed for both external check corners and stop end for gutter.

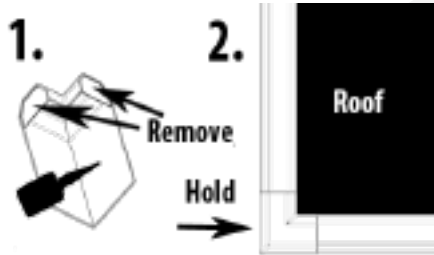

External Corner

- Mitre the trims so they fit together with foam seal compressing between the two trim ends.
- Remove the two blanking plates.
- Apply adhesive to one side of the corner.
- Fit over trims and hold in place till set.

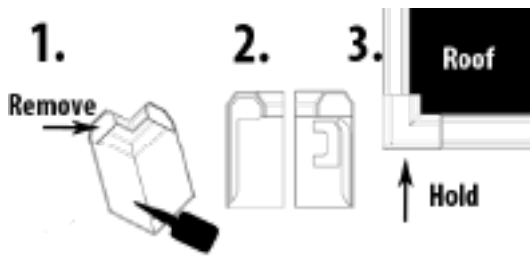

Stop End

- Remove one blanking plate for the relevant side.
- Apply adhesive to one side of the corner.
- Fit over trims and hold in place till set.

FIX-R

FLAT ROOFING

EPDM

- Large seamless single ply sheets
- Flame free installation
- Will not rot, split or degrade
- Not affected by extremes of temperature
- Life expectancy of 50 years
- Little or no maintenance
- Highly flexible

All the information in this product sheet is based on practical experience and is published in good faith. However, because we have no control over the manner or conditions in which our products are used, or over work undertaken or end product manufactured by the purchaser, we cannot accept liability for results. Responsibility for ascertaining the suitability of products for their purposes rests with the purchaser. All conditions, representations, statements, warranties or guarantees whatsoever, whether express, implied or statutory, in respect of any goods manufactured, sold or supplied by us are hereby expressly excluded and we accept no liability in respect of any claim for damage or consequential loss caused to any property arising directly or indirectly out of the use of our products or goods. VERS 1. 03/2019